

temps de front

$$T1 = 1,2 \text{ s} - 30\%$$

temps de queue

$$T2 = 50 \text{ s} - 20\%$$

relation entre T1 et T

$$T1 = 1,67 T$$

Partial discharge level from day 1 ≤ 10 pC
 Insulation 24 kV : impulse tested at 125 kV
 Insulation 36 kV : impulse tested at 170 kV,
 200 kV indeed.

electrical tests

These tests verify contractual electrical characteristics. They include :

■ individual tests (or routine tests).
 These tests are systematically carried out on all Trihal transformers at the end of manufacturing and are subject to an official test report (see specimen on the next page). They consist of :

- measurement of characteristics :
 - resistance of windings ;
 - transformation ratio and vector group ;
 - impedance voltage ;
 - load losses ;
 - no load losses and no load current.

- dielectric tests :
 - applied voltage tests ;
 - induced voltage tests ;
 - measurement of partial discharge, acceptance criterion : 10 pC at 1.30 Ur, rated voltage. The acceptance criteria is set at 10 pC by standard IEC 60076-11 § 22.5.

■ type test.
 They are carried out on request and are at the clients expense.

□ lightning test⁽¹⁾
 The impulse test voltage is usually of negative polarity. The test sequence is composed of a calibration impulse between 50 % and 75 % of the full voltage followed by three impulses at full voltage.
 The applied is full standardized lightning impulse, see diagram.
 Trihal's basic offer proposes a choice of impulse withstand levels as standard, according to list 2 (see table below), i.e. for 36 kV an impulse test voltage of 170 kV, with the possibility of taking these values to 200 kV impulse for an insulation level of 38.5 kV.

□ temperature rise test
 Carried out according to the simulated loading method. Heating measured by two tests :
 - one with only no load losses ;
 - the other with only load losses.
 The total temperature rise is calculated in accordance with IEC 60076-11.



Ennery test line

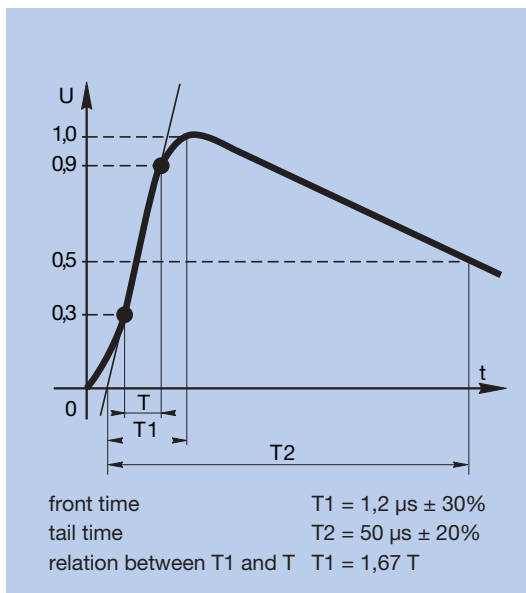

full wave lightning impulse

1) summary of standard test levels

system highest voltage (kV)	3.6	7.2	12	17.5	24	36	41,5
eff. kV 50 Hz - 1 mm	10	20	28	38	50	70	80
impulse kV 1,2/50 μs							
List 1	20	40	60	75	95	145	
List 2	40	60	75	95	125	170	200

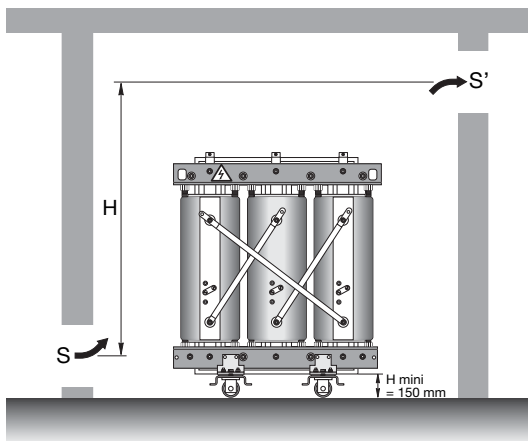

figure 1 - substation natural ventilation

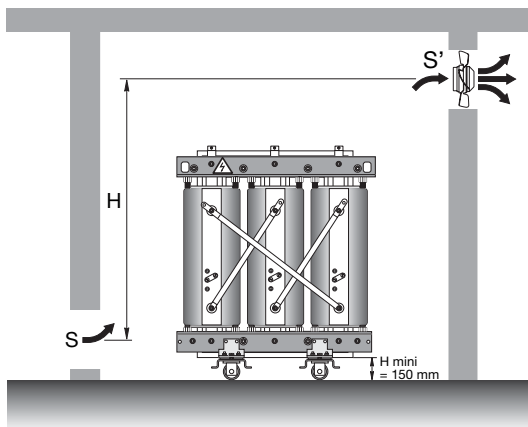

figure 2 - substation forced ventilation

substation ventilation

- determination of the height and area of ventilation grills.

In the general case of natural cooling (AN), the ventilation of the substation or of the enclosure must ensure by natural convection the dissipation of the heat produced by the transformer's total losses.

In the case of a sufficiently ventilated substation, appropriate ventilation will consist of a fresh air intake opening of S section at the bottom of the substation and an outgoing air opening S' located above on the opposite wall at height H metres above the intake opening (figures 1 and 2).

To ensure efficient cooling of the transformer and sufficient air circulation, it is essential to maintain a minimum height of 150 mm under the live section, by installing rollers or an equivalent booster.

It must be noted that restricted air circulation reduces the transformer's continuous and short term overload capacity.

- formula for ventilation (figure 1) :

$$S' = \frac{0.18 P}{\sqrt{H}} \text{ and } S' = 1.10 \times S$$

P = sum of the transformer's no-load and load losses expressed in kW at 120°C.

S = area of the lower air intake opening (allow for mesh factor) expressed in m².

S' = area of the air outlet opening (allow for mesh factor) expressed in m².

H = height difference between the two openings expressed in metres.

This formula is valid for an average ambient temperature of 20°C and an altitude of 1000 m.

Example :

- one single Trihal transformer 1000 kVA,
- P_o = 2300 W, P_{cc} at 120°C = 11000 W,
- i.e. P = 13.3 kW.

If the distance between the grills = 2 m, then S = 1.7 m² of net surface area necessary.

If we imagine a grill obstructing the air inlet by 30% ; the air inlet grill surface area should then be 1.5 m × 1.5 m, and that of the air outlet should be 1.5 m × 1.6 m.

- substation forced ventilation (figure 2) :

Forced ventilation of the substation is necessary for ambient temperatures above 20°C, or small or badly ventilated rooms for applications with frequent overloads.

The fan can be thermostat controlled and operate as an extractor in the top part of the room.

Advised flow (m³/second) at 20°C = 0,1 × P.

P = sum of the transformer's no-load and load losses expressed in kW at 120°C.

overloads

admissible temporary overloads for daily load cycle

acceptable short time overloads

annual ambient temperature + 10C

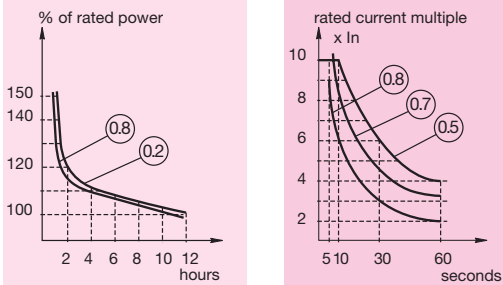

annual ambient temperature

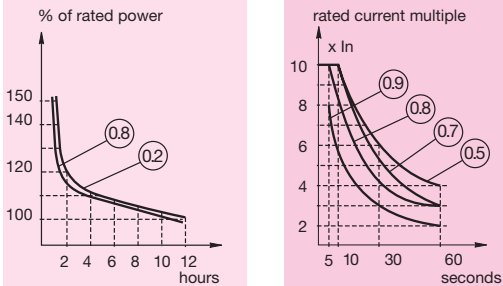

annual ambient temperature - 10C

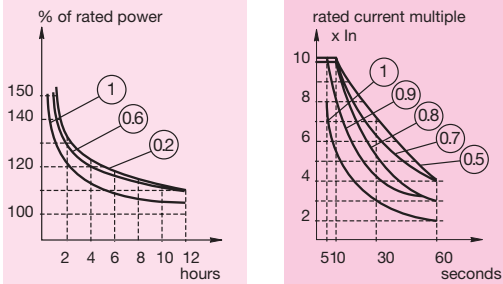

overloads graphs according to the ambient temperature

general information

The transformers are designed to operate at rated power at ambient temperature defined by IEC 60076 :

- maximum : 40°C ;
- daily average : 30°C ;
- yearly average : 20°C.

Without particular specification, the reference temperature is the annual average of 20°C.

■ overloads are allowed without reducing the transformer's service life if they are compensated by a normal load below the rated power (description in IEC 60905 standard).

$$K = \frac{\text{load}}{\text{rated power}}$$

The admissible overloads are also subject to the average mean ambient temperature. The 1st column gives the cyclical daily overloads.

The 2nd column indicates the acceptable short time overloads.

■ the figure below shows the acceptable constant load as a function of the average temperature compatible with normal life duration.

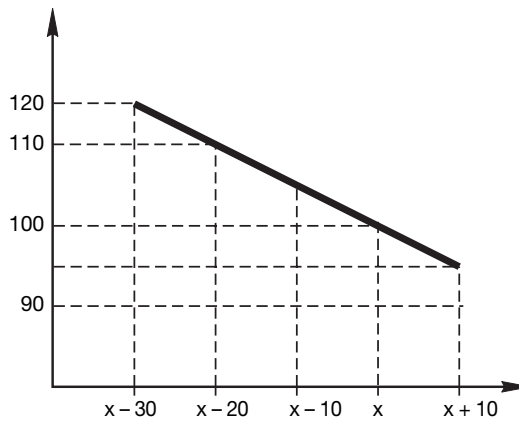

ambient temperature in °C
(x = annual average temperature)

■ one can operate a transformer designed for operation in yearly average ambient temperature of 20°C at higher temperatures by reducing the rating as shown in the table :

yearly average ambient temperature	admissible load
20°C	P
25°C	0.97 x P
30°C	0.94 x P
35°C	0.90 x P

HV/LV distribution transformers

TRIHAL cast resin dry type transformers 160 to 3150 kVA
 insulation level \leq 24 kV - low voltage 400 to 433 V - 50 Hz
 thermal class F - ambient \leq 40°C, altitude \leq 1000 m



standards

- In accordance with standards:
- IEC 60076-1 to 60076-5;
 - IEC 60076-11 (2004);
 - CENELEC (European Committee for Electrotechnical standardization) harmonization documents HD 538-1 S1: 1992 and EN 60726: 2003 / A2: 1991 / A3: 1992 concerning dry type transformers.
 - IEC 60905.



common electrical characteristics

frequency ⁽¹⁾	50Hz
maximum ambient temperature	40°C
secondary voltage at no load ⁽¹⁾	400 to 433V between phases, 231 to 250V phase to neutral
HV tapping range (off-circuit) ⁽¹⁾	$\pm 2.5\%$, $\pm 5\%$
vector group	Dyn (delta, star neutral brought out)
partial discharges ⁽⁵⁾	≤ 10 pC at 1.3 Un

electrical characteristics for insulation level: 7.2 kV and 12 kV

rated power (kVA) ^{(1) (*)}	160 ⁽²⁾	250	400	630	800	1000	1250	1600	2000	2500	3150	
rated primary voltage ⁽¹⁾	5 to 11kV (dual voltage on request)											
rated insulation level ⁽³⁾	7.2kV for 5kV - 12kV for 11kV											
losses (W)	no load losses	610	820	1150	1370	1700	2000	2500	2800	3500	4300	5200
	load losses at 75°C	2300	3100	4300	6700	7700	8800	10500	12300	14900	18300	21800
	load losses at 120°C	2700	3500	4900	7600	8800	10000	12000	14000	17000	21000	25000
rated impedance voltage (%)	4	4	4	6	6	6	6	6	6	6	6	
no-load current (%)	2.3	2	1.5	1.3	1.3	1.2	1.2	1.2	1.1	1	1	
switching current	le/In (peak value)	13.5	13	13	10	10	10	10	9	9	9	9.5
	time constant	0.13	0.18	0.25	0.3	0.3	0.34	0.35	0.42	0.45	0.5	0.5
efficiency (%)	load 100% cos φ = 0.8 at 120°C	97.48	97.89	98.14	98.25	98.39	98.52	98.57	98.70	98.73	98.75	98.82
	load 75% cos φ = 0.8 at 120°C	97.83	98.17	98.40	98.53	98.63	98.75	98.78	98.90	98.92	98.94	98.99
noise level ⁽³⁾	acoustic power LWA	62	65	68	70	72	73	75	76	77	81	81
	dB(A) acoustic pressure LPA at 1 m	53	54	56	57	59	60	61	62	62	66	66

electrical characteristics for insulation level: 17.5 kV and 24 kV

rated power (kVA) ^{(1) (*)}	160 ⁽²⁾	250	400	630	800	1000	1250	1600	2000	2500	3150	
rated primary voltage ⁽¹⁾	15 to 22kV (dual voltage on request)											
rated insulation level ⁽³⁾	17.5kV for 15kV - 24kV for 22kV											
losses (W)	no load losses	650	880	1200	1650	2000	2300	2800	3100	4000	5000	6300
	load losses at 75°C	2350	3300	4800	6800	8200	9600	11400	14000	17400	20000	23000
	load losses at 120°C	2700	3800	5500	7800	9400	11000	13100	16000	20000	23000	26000
rated impedance voltage (%)	6	6	6	6	6	6	6	6	6	6	6	
no-load current (%)	2.3	2	1.5	1.3	1.3	1.2	1.2	1.2	1.1	1	1	
switching current	le/In (peak value)	10.5	10.5	10	10	10	10	10	10	9.5	9.5	9.5
	time constant	0.13	0.18	0.25	0.26	0.3	0.3	0.35	0.4	0.4	0.5	0.5
efficiency (%)	load 100 % cos φ = 0.8 at 120°C	97.45	97.71	97.95	98.16	98.25	98.36	98.43	98.53	98.52	98.62	98.73
	load 75% cos φ = 0.8 at 120°C	97.79	98.03	98.24	98.43	98.50	98.61	98.66	98.76	98.75	98.82	98.90
noise level ⁽³⁾	acoustic power LWA	62	65	68	70	72	73	75	76	78	81	81
	dB(A) acoustic pressure LPA at 1 m	51	53	56	57	59	59	61	62	63	66	66

(*) the rated power is defined by natural air cooling (AN). Should there be particular constraints, it may be increased by 40 % by forced cooling addition (AF). Please consult us.
 (1) other possibilities upon request, consult us.
 (2) non standard ratings available on request.

(3) reminder of insulation levels:

rated insulation level (kV)	7.2	12	17.5	24
kV r.m.s. 50 Hz - 1 mn	20	28	38	50
kV B.I.L. 1.2/50 μ s	60	75	95	125

(4) according to IEC 551.
 (5) according to IEC 270.

HV/LV distribution transformers

TRIHAL cast resin dry type transformers 160 to 3150 kVA
 insulation level ≤ 24 kV - low voltage 400 to 433 V - 50 Hz
 thermal class F - ambient $\leq 40^\circ$ C, altitude ≤ 1000 m

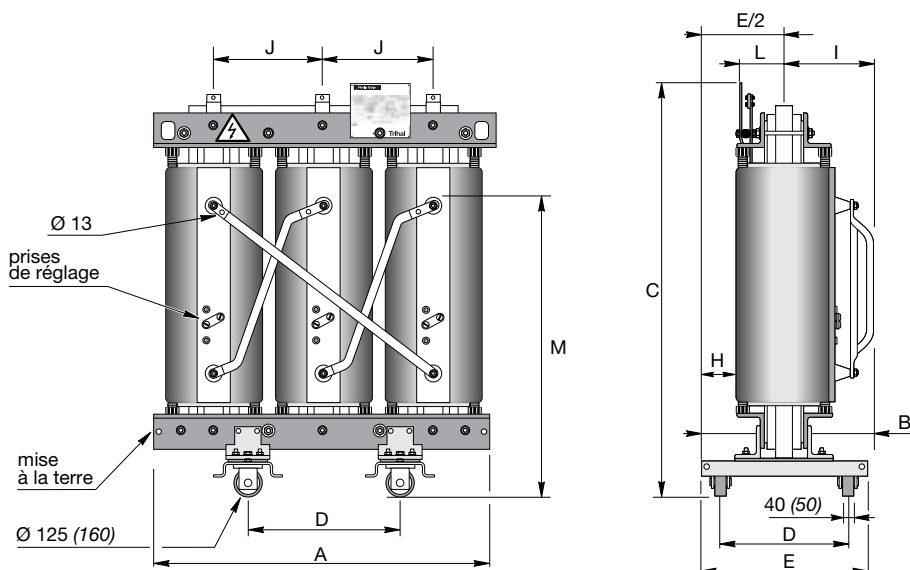

dimensions and weights without enclosure housing (IP00)

Dimensions and weights indicated in the table below are provided as an example for single voltage transformers with insulation level 12kV (1st table) and 24 kV (2nd table), according to electrical characteristics shown page 1. Consequently, these tables give you approximate dimensions and weights for insulation level from 7.2 to 12kV (1st table) and from 17.5 to 24kV (2nd table). Only the definitive drawings following from the order will commit us contractually. For other voltages, impedance voltages and dual-voltages, weights and dimensions are different (consult us).

insulation level: 7.2 kV and 12 kV - low voltage 400 V to 433 V

rated power (kVA)		160	250	400	630	800	1000	1250	1600	2000	2500	3150
dimensions (mm)	Lenght A	1290	1315	1325	1425	1455	1525	1605	1665	1760	1870	2100
	Width B	700	705	795	810	825	945	945	945	1195	1195	1195
	Connection height or Maximum height C	1325	1335	1345	1540	1650	1675	1860	2035	2180	2270	2345
	Roller pitch D	520	520	670	670	670	820	820	820	1070	1070	1070
	Frame width E	645	645	795	795	795	945	945	945	1195	1195	1195
	Roller diam. F	125	125	125	125	125	125	125	125	160	160	160
	Roller width G	40	40	40	40	40	40	40	40	50	50	50
Weight without enclosure (kg)		860	955	1185	1630	1770	2125	2580	3210	3910	4480	6750

insulation level: 17.5 kV and 24 kV - low voltage 400 V to 433 V

rated power (kVA)		160	250	400	630	800	1000	1250	1600	2000	2500	3150
dimensions (mm)	Lenght A	1290	1315	1420	1480	1540	1630	1615	1825	1885	1975	2295
	Width B	700	705	805	820	830	945	945	950	1195	1195	1195
	Connection height or Maximum height C	1325	1335	1425	1735	1745	1795	2065	2060	2325	2345	2400
	Roller pitch D	520	520	670	670	670	820	820	820	1070	1070	1070
	Frame width E	645	645	795	795	795	945	945	945	1195	1195	1195
	Roller diam. F	125	125	125	125	125	125	125	125	160	160	160
	Roller width G	40	40	40	40	40	40	40	40	50	50	50
Weight without enclosure (kg)		860	955	1295	1695	1930	2350	2750	3670	4495	4975	7700

HV/LV distribution transformers

TRIHAL cast resin dry type transformers 160 to 3150 kVA
 insulation level ≤ 24 kV - low voltage 400 to 433 V - 50 Hz
 thermal class F - ambient $\leq 40^\circ$ C, altitude ≤ 1000 m

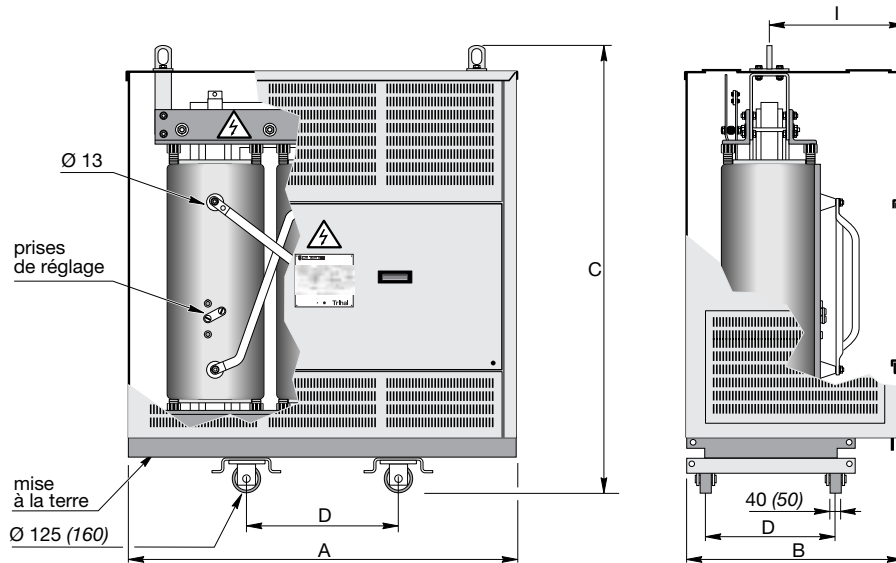

dimensions and weights with IP31 metal enclosure

Dimensions and weights indicated in the table below are provided as an example for single voltage transformers with insulation level 12kV (1st table) and 24 kV (2nd table), according to electrical characteristics shown page 1. Consequently, these tables give you approximate dimensions and weights for insulation level from 7.2 to 12kV (1st table) and from 17.5 to 24kV (2nd table). Only the definitive drawings following from the order will commit us contractually. For other voltages, impedance voltages and dual-voltages, weights and dimensions are different (consult us).

insulation level: 7.2 kV and 12 kV - low voltage 400 V to 433 V

rated power (kVA)		160	250	400	630	800	1000	1250	1600	2000	2500	3150
dimensions (mm)	Lenght A	1650	1650	1700	1700	1700	2000	2000	2150	2330	2330	2600
	Width B	950	950	1020	1020	1020	1170	1170	1170	1270	1270	1270
	Height C	1750	1750	1900	1900	1900	2400	2400	2480	2650	2650	2650
	Roller pitch D	520	520	670	670	670	820	820	820	1070	1070	1070
	Frame width E	645	645	795	795	795	945	945	945	1195	1195	1195
	Roller diam. F	125	125	125	125	125	125	125	125	160	160	160
	Roller width G	40	40	40	40	40	40	40	40	50	50	50
Total weight (kg)		1040	1135	1380	1825	1965	2390	2845	3535	4280	4850	7200

insulation level: 17.5 kV and 24 kV - low voltage 400 V to 433 V

rated power (kVA)		160	250	400	630	800	1000	1250	1600	2000	2500	3150
dimensions (mm)	Lenght A	1650	1650	1700	1800	1800	2000	2150	2150	2330	2330	2600
	Width B	950	950	1020	1020	1020	1170	1170	1170	1270	1270	1270
	Height C	1750	1750	1900	2050	2050	2400	2480	2480	2650	2650	2650
	Roller pitch D	520	520	670	670	670	820	820	820	1070	1070	1070
	Frame width E	645	645	795	795	795	945	945	945	1195	1195	1195
	Roller diam. F	125	125	125	125	125	125	125	125	160	160	160
	Roller width G	40	40	40	40	40	40	40	40	50	50	50
Total weight (kg)		1040	1135	1490	1905	2140	2615	3070	3995	4860	5340	8150

HV/LV distribution transformers

TRIHAL cast resin dry type transformers 160 to 3150 kVA
insulation level ≤ 24 kV - low voltage 400 to 433 V - 50 Hz
thermal class F - ambient $\leq 40^\circ$ C, altitude ≤ 1000 m

minimum clearances required

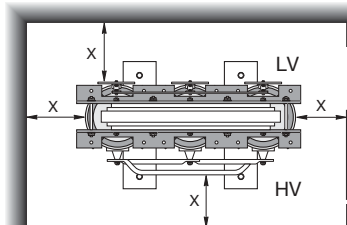

insulation (kV)	dimensions X (mm)	
	full wall	grid wall
7.2	90	300
12	120	300
17.5 - 24	220	300

According to HD 637-1

Don't take into account the access to tapping on the UV side.

HV and LV standard connection

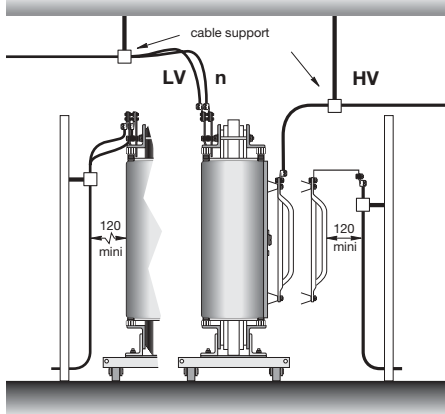

connections

TRIHAL transformers without enclosure housing (IP 00)

The winding resin coating and the plug-in connectors don't ensure any protection against touch when the transformer is energized.

The contractor must ensure that cables and busbars are adequately supported to prevent mechanical stresses from being imposed on the transformer terminals, busbars or bushings.

minimum clearances required

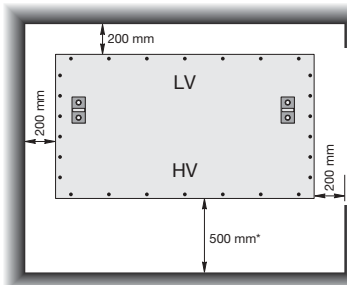

*500 mm. for an access to tapping on the HV side, but 200 mm. minimum.

HV and LV connection

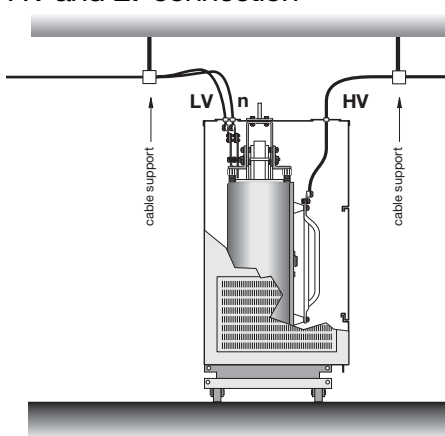

TRIHAL transformers with IP 31 metal enclosure

LV terminations

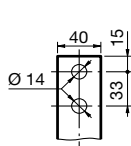

160 to 400 kVA*
thickness 5

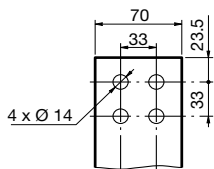

500 to 800 kVA*
thickness 6

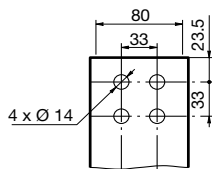

1000 to 1250 kVA*
thickness 10

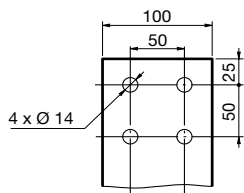

1600 kVA*
thickness 12

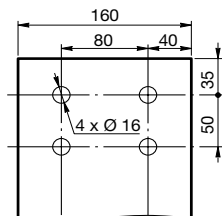

2000 kVA* thickness 10
2500 kVA* thickness 2 x 10

*Valid for aluminium terminations.

HV terminations

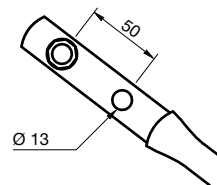

The contractor must ensure that cables and busbars are adequately supported to prevent mechanical stresses from being imposed on the transformer terminals, busbars or bushings.

Schneider Electric Industries SAS

Adresse postale :
france transfo
 BP 10140
 F-57281
 Maizières-lès-Metz cedex
 France
 tél : 33 (0)3 87 70 57 57
 fax: 33 (0)3 87 51 10 16
 http://www.schneider-electric.com

Due to the evolution of standards and materials, the present document will bind us only after confirmation from technical department.

Publication : Schneider Electric SAS
 Conception, réalisation : COREDIT
 Impression : imprimerie Tecnodim
GEa 26 k



Wind turbines and Trihal transformer, bring a breath of fresh air to safety



- A compact design facilitating its installation and access (in the nacelle or in the pole tower)
- Extremely resistant to overloads and temperature variations
- Excellent withstand to vibrations validated in an independent laboratory
- Exceptional fire behaviour (class F1)
- Absolutely no liquid dielectric
- A 5-year guarantee*



Trihal, the only guarantee against the risk of fire



* on completion and validation of the commissioning check list, and after expert appraisal and approval

More than 2000 Trihal dry type cast resin transformers in operation in the wind turbine sector