



**n° 180**

**earthquakes  
and electrical  
equipment**

**Eric MELMOUX**

**Graduated in mechanical engineering from the «INSA» School, Lyon in 1981, and obtained a DEA (equivalent to 1st year of Phd) in «vibrations» the same year. After ten years spent with a company which specialises in sound and vibrations, he joined Merlin Gerin. He is, at present, head of the «shocks and vibrations» group at Schneider Electric.**

## **glossary**

---

<b>Epicenter</b>	point at ground level, vertically above the hypocenter.
<b>Frequency appropriation</b>	excitation frequency corresponds with resonance frequency of the structure.
<b>Hypocenter or seismic focus</b>	position of the earthquake in the earth's crust.
<b>Intensity</b>	measures the force of the earthquake in terms of the effects produced (MERCALLI scale).
<b>LOVE Waves</b>	correspond to the horizontal component of the surface waves.
<b>Magnitude</b>	measures the force of the earthquake in terms energy released at the seismic focus (RICHTER scale).
<b>Meshing</b>	action whereby a complex structure is broken down into its beam gantrys - plates - volume.
<b>MHEL</b>	Maximum Historical Earthquake Likelihood for a site.
<b>Modal shape</b>	oscillating deformation adopted by an elastic structure during excitation on one of its resonance frequencies.
<b>Qualification</b>	process which consists in establishing the appropriate withstand capabilities for equipment with required or normal stresses.
<b>RAYLEIGH Waves</b>	correspond to the vertical component of the surface waves.
<b>Response Spectrum</b>	device which enables a characterization of the earthquake to be effectuated in terms of its effects on a simple structure.
<b>Seismic Activity</b>	violent movement of tectonic plates which produces an earthquake.
<b>Single DOF mechanical system</b>	single degree of freedom structure characterized by mass, spring and damper.
<b>Space appropriation</b>	excitation forces apply pressure on the antinodes of the modal shape.
<b>SSE</b>	Safe Shutdown Earthquake (MHEL plus one degree on the MERCALLI scale).
<b>Strong part of response spectrum</b>	corresponds to the frequencies which cause the structure to amplify ground movements.
<b>Time-history</b>	recording of ground acceleration during the earthquake.
<b>Zero Period Acceleration ZPA part</b>	corresponds, on a response spectrum, to the frequencies which cause the structure to trace ground accelerations without amplification of motion.

---

# earthquakes and electrical equipment

## contents

<b>1. Earthquakes</b>	Causes - location	p. 4
	Propagation of seismic waves	p. 4
	Characteristics of vibrations generated at ground level	p. 4
	Intensity and magnitude	p. 4
	Seism characterization	p. 6
	Defining the seismic severity of a site	p. 8
	Reading the response spectrum applicable to a piece of equipment	p. 9
<b>2. Dynamic behaviour of structures</b>	Brief summary of single degree of freedom oscillator	p. 12
	Elastic structures (with N degrees of freedom)	p. 12
<b>3. Equipment design</b>	Defining objectives	p. 16
	Design principles	p. 16
	Simulation by analysis at design stage	p. 18
<b>4. Qualification by simulation or test</b>	Introduction	p. 20
	Combined qualification (numerical analysis and experimental tuning)	p. 20
	Qualification by «real size» tests preceded by numerical analysis	p. 21
	Qualification by test	p. 22
<b>5. Conclusion</b>		p. 25
<b>6. Bibliography</b>		p. 26

In all countries there is either a zone of significant seismic activity or installations which require high security in order to operate (e.g. nuclear power stations, which generally have low seismic activity). In both cases the electrical and control and monitoring equipment must assure their safety functions correctly.

This technical paper aims to facilitate dialogue between operators and specialists.

After briefly summarizing the earthquake phenomena and the way in which they are specified, the author presents the theoretic approach required for seismic withstand capabilities to be taken into account at the design stage.

Both design and qualification are, today, increasingly requiring numerical analysis and, as a result, powerful scientific and technical data processing methods.

# 1. earthquakes

## causes - location

The majority of earthquakes occur on the fault lines which demarcate the tectonic plates from the earth's crust. Tension accumulates when the plates slowly shift away from each other. The sudden release of distorting energy which has thus accumulated inside the earth's crust, or in the underlying layer called the mantle, provokes a local agitation. Some of this energy is then transformed into seismic waves at the surface of the ground.

It is the creation of a fault line, or more frequently the slide along an existing fault line, which constitutes the generating mechanism of an earthquake. The place where it occurs is called the **seismic focus** or the **hypocenter** and the projection from this point to the ground is called the **epicenter** (see fig. 1).

The depth of the hypocenter varies greatly: from a few kilometres to up to 100 km.

## propagation of seismic waves

Earthquakes propagate in waves which, taking the heterogeneity of the ground into account, provoke a complex vibratory movement at the surface which is difficult to predict for a given site.

A distinction is made between two types of wave: bulk waves and surface waves.

### Bulk waves

They originate at the seismic focus and propagate inside the earth's mantle in two different forms:

- longitudinal waves characterised by alternating compressions and dilations which propagate at a speed of 7 to 8 km/s,
- transversal waves characterised by a plane distortion perpendicular to the

direction of the propagation, which provoke shear and propagate at a speed of 4 to 5 km/s (see fig. 2).

### Remark:

It is the difference in speed between the longitudinal and transversal waves and recordings taken from several seismographs, which enables an earthquake's seismic focus to be located.

### Surface waves

These are generated by the bulk waves which reach the surface and propagate at a speed of 1.5 to 5 km/s.

A distinction is made between:

- RAYLEIGH waves which cause the ground points to describe ellipses in the vertical plane; they engender compression and shear in the ground,
- LOVE waves which cause the ground points to shift at a tangent to the surface, perpendicular to the propagation direction; they engender shear only (see fig. 2).

## characteristics of vibrations generated at ground level

In reality things are far more complex; the propagation of a seismic wave in a heterogeneous environment provokes a complex system of refracted and reflected waves for each discontinuity, so that the seismic movement is completely random at ground level.

However, vibratory movements brought about at ground level by earthquakes do produce common characteristics, and a certain number of parameters are generally employed to describe them.

### Characteristics of random vibrations provoked at ground level by an earthquake:

#### ■ direction

The movement is made up of simultaneous independent vertical and horizontal components;

#### ■ duration

It is usually between **15 and 30 s** (an intense earthquake can last between 60 and 120 seconds).

#### ■ frequency

Broad band random movement produces preponderant energy between **1 and 35 Hz**, and provokes the most destructive effects at between **1 and 10 Hz**.

#### ■ level of acceleration

There is no correlation between the waves observed in the two different directions: at any given moment the amplitudes and frequencies are independent.

Horizontal ground acceleration is generally lower than 0.5 g (exceptionally higher than 1g, or 10 m/s<sup>2</sup>).

Vertical acceleration has a lower amplitude. Observations show that the relationship between the maximum vertical and horizontal amplitudes is in the order of  $\frac{2}{3}$  (for frequencies higher than 3.5 Hz).

## intensity and magnitude

### Intensity

The scale of an earthquake is generally measured in terms of its intensity at the observation site. This subjective evaluation is established in terms of the effects felt by the population and the damage incurred.

Different intensity scales have been defined, which class the seismic effects in order of increasing size, with the help of some conventional descriptions:

■ the **MERCALLI** scale describes commonly observed effects on the environment, buildings and man after an earthquake,

■ the **MSK** scale (or modified Mercalli scale), more precise than the original, includes an evaluation of the damage,

the type of building and percentage of buildings affected.

These estimations are useful for assessing the size of earthquakes if there are no time-histories or spectra available. They do not enable the seismic load of a site to be specified.

**Magnitude**

Another method of determining the scale of an earthquake is to establish its **magnitude**, the intrinsic characteristic of an earthquake which measures the total energy released. Magnitude, defined in 1935 by **RICHTER**, and the scale which ensued, are used universally.

Magnitude is, in practice, determined according to ground movement recordings taken at a number of observation points at various distances from the epicenter.

From these observations seismologists calculate the energy E (expressed in ergs) of the earthquake, from which the magnitude M is deduced.

The simplified empirical equation:  $\log E = 9.9 + 1.9 M + 0.024 M^2$  gives an approximate, but rapid calculation.

**Intensity / maximum ground acceleration / seismic zone correlation**

The table in figure 3 (see overleaf) establishes a correlation between the various subjective levels of intensity in the modified **MERCALLI** scale and the maximum ground acceleration level responsible for the damage observed. This table also indicates the type of seismic activity zones prone to such seismic intensity (see fig. 4, page 7 for the division of the world's seismic activity zones).

**Intensity / magnitude correlation**

Theoretically, no relationship can exist between intensity and magnitude; intensity is dependent on the distance from the site in question to the seismic focus, on soil type, the type of foundations used, the type of building and the duration of the earthquake. However, an approximate correlation is proposed by the experts (see table in figure 5, page 7).

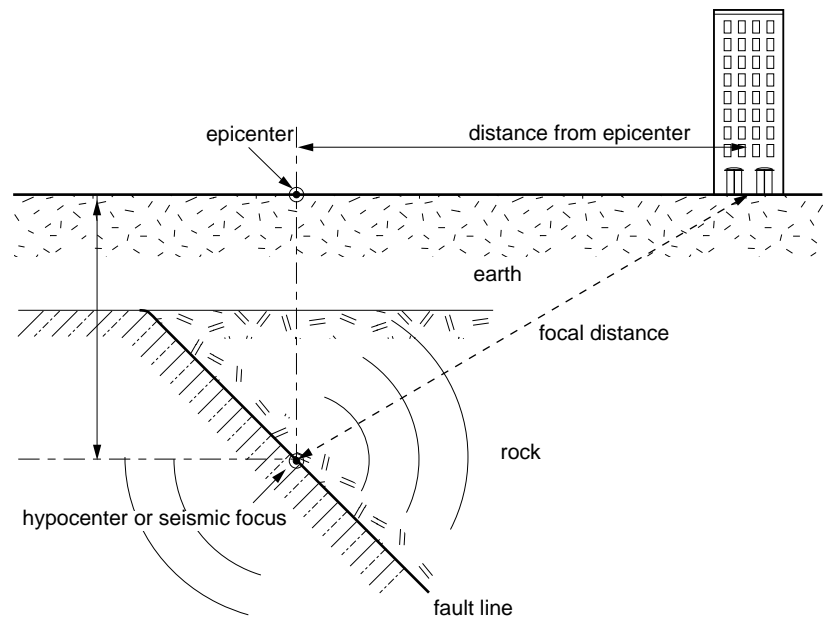

fig.1: geosismic vocabulary and characteristic features.

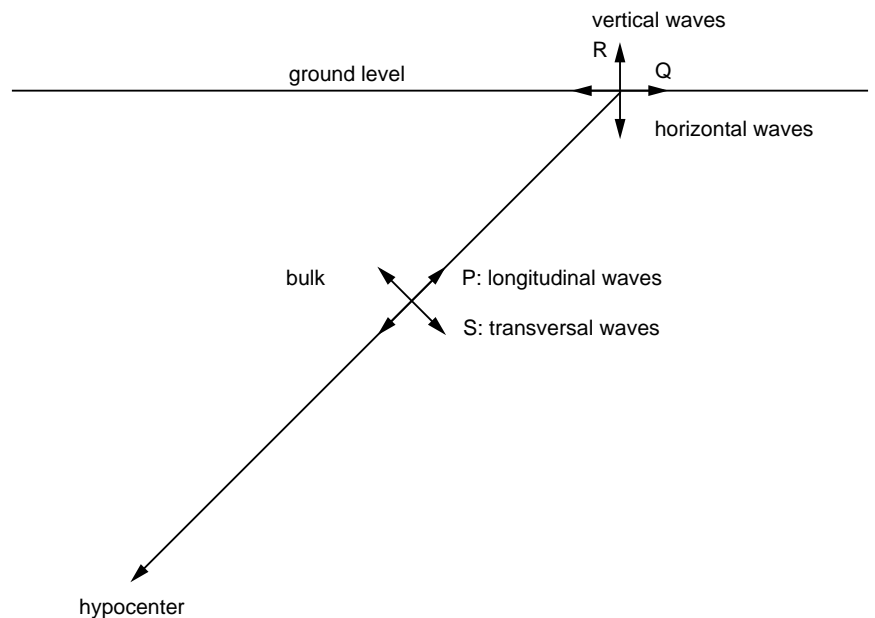

fig.2: seismic bulk and surface waves.

intensity	modified Mercalli scale	approximate horizontal acceleration values in m/s <sup>2</sup>	seismic zone
1	Tremor not felt.		zone 0
2	Tremor felt by those resting or situated on top floors.		
3	Hanging objects move. Slight vibrations.		
4	Vibrations similar to those provoked by a heavy lorry passing are felt. Window panes and crockery rattle. Stationary vehicles sway.	2	zone 1
5	Tremor felt outside buildings. Those sleeping are woken up. Small objects fall down. Pictures are tipped sideways.		
6	Tremor felt by everyone. Furniture is moved. Damage: broken glass, objects thrown from shelves, slight cracks appear in plastering.		zone 2
7	Tremor felt in moving vehicles. Those standing fall off balance, church bells ring. Damage: chimneys and other external architecture break away, plaster falls down, broken furniture, extended cracks in plastering and masonry, some houses in brick collapse.		
8	Drivers in moving vehicles experience difficulties. Branches fall from trees. Fissures appear in waterlogged ground. Destruction: water towers, monuments, brick houses. Slight to substantial damage: brick buildings, prefabricated houses, irrigation works, causeways.	3	zones 3 and 4
9	«Sand craters» in sandy and waterlogged ground in urban areas. Landslides. Fissuring in ground. Destruction: non-reinforced brick masonry. Slight to substantial damage: insufficiently reinforced concrete structures, underground piping.		
10	Landslides and major ground destruction. Destruction: bridges, tunnels, certain reinforced concrete structures. Slight to substantial damage: the majority of buildings, dams, railway lines.	5	
11	Permanent ground deformation.		
12	Almost total destruction.		

Seismic zones correspond to the anticipated level of intensity according to observations carried out over a period of 200 years.

fig. 3: Mercalli scale.

## seism characterization

Intensity, magnitude or maximum ground accelerations do not suffice when estimating the risks to a building or a piece of equipment. In fact, in order to estimate the response of a given structure, a more detailed knowledge of the duration and frequency of the ground movement is required.

There are two methods for characterizing ground movement:

- time-history:  $\gamma = f(t)$ ;

- response spectrum which characterizes the **effects** produced by the seism on an elementary structure (1st order linear mechanical system).

### Time-history

Ground acceleration evolution as a function of time (see fig. 6). This type of information, recorded by seismographs according to the three spatial directions, is used to estimate the seismic risk incurred by equipment, when determining the withstand either by test or analysis.

The time-history is the only possible option for determining the chronology of a structure's response to seismic excitation, which is required when ascertaining the evolution of the different components' relative displacement over time.

However, this rarely figures in specifications sheets either because it is not available or because it does not lend itself to the seismic severity calculations of a site.

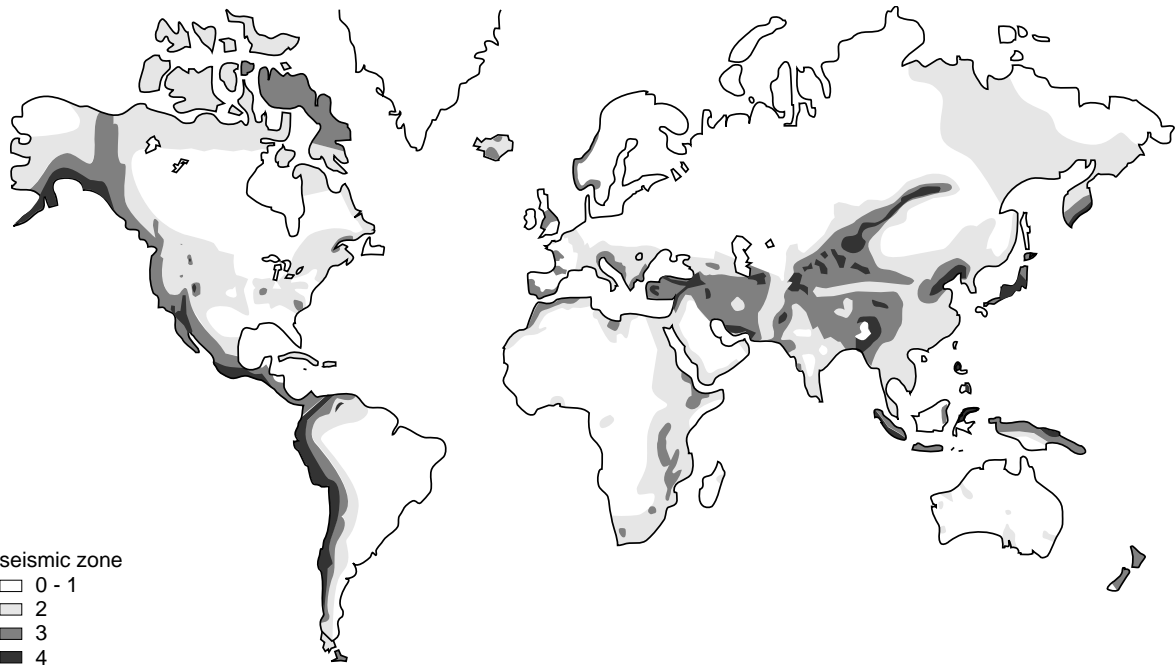

fig. 4: seismic activity zones in the world.

<b>Mercalli (intensity)</b>	1	2	3	4	5	6	7	8	9	10 - 11 - 12
<b>Richter (magnitude)</b>	0-2	1-2	2-3	3-4	4-5	5-6	5-7	6-8	7-9	> 8

The correlations between the Mercalli and Richter scales are completely indicative because they depend on soil type, distance from the seismic focus (from 5 to 100 km), and earthquake duration.

fig. 5: «indicative» correlation between Mercalli and Richter scales.

### Response spectrum

The response spectrum allows the earthquake to be characterized in terms of the effects it produces on equipment. For this, the effect of the time-history (in seismic waves) is calculated on standardized equipment, that is to say, on an array of single degree of freedom oscillators, characterised by their resonance frequency and damping values.

A single DOF system is characterized by: a mass  $M$ , spring  $K$  and damper  $\lambda$ ; its resonance frequency is:

$$Fr = \frac{1}{2\pi} \sqrt{\frac{K}{M}}$$

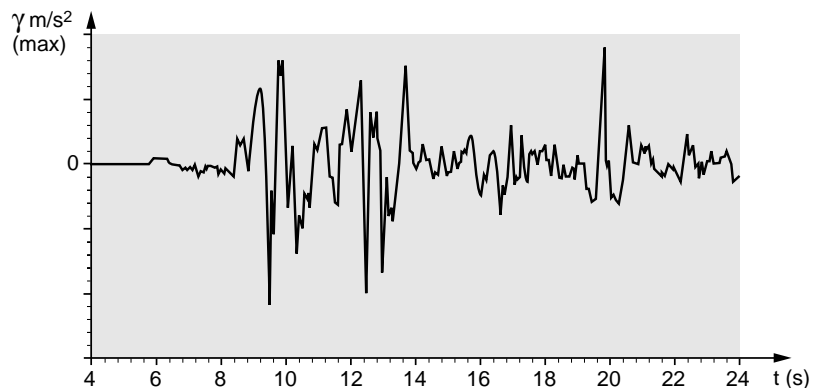

fig. 6: sample time history  $\gamma = f(t)$  record of horizontal north-south ground acceleration, El Centro - California, Mai 18, 1940.

The maximum response of this system to the seismic wave (maximum acceleration of mass) gives one point on the response spectrum (see fig. 7). By varying the resonance frequency (K/M), the curve obtained:

$\gamma_{max} = f(Fr)$  (see fig. 8) is the response spectrum which characterizes the severity of the seismic wave for a given damping.

Figure 9 shows the family of curves obtained when the damping is modified. The response spectrum generally figures in specifications sheets, so that it can be applied in horizontal directions. The vertical response spectrum is deduced by using a coefficient.

The response spectrum is the most widely used tool today for determining the seismic severity of a site, because it lends itself naturally to:

- severity comparison,
- elaboration of severity envelopes for several sites,
- simple severity increases,
- approximate estimates of seismic effects on equipment (damage potential).

**Remark:**

The response spectrum must not be confused with the FOURIER series expansion of a periodic phenomenon, or the FOURIER transform of an aperiodic phenomenon, which are not used in seismic studies.

**defining the seismic severity of a site**

**Safe Shutdown Earthquake (SSE) - Maximum Historical Earthquake Likelihood (MHEL)**

Defining the seismic severity of a site generally requires the site's geological data and seismic history.

In France for example, data from the exceptionally well documented seismic history (100 years) enables the seismic risk of a site to be established.

This allows the Maximum Historical Earthquake Likelihood to be defined

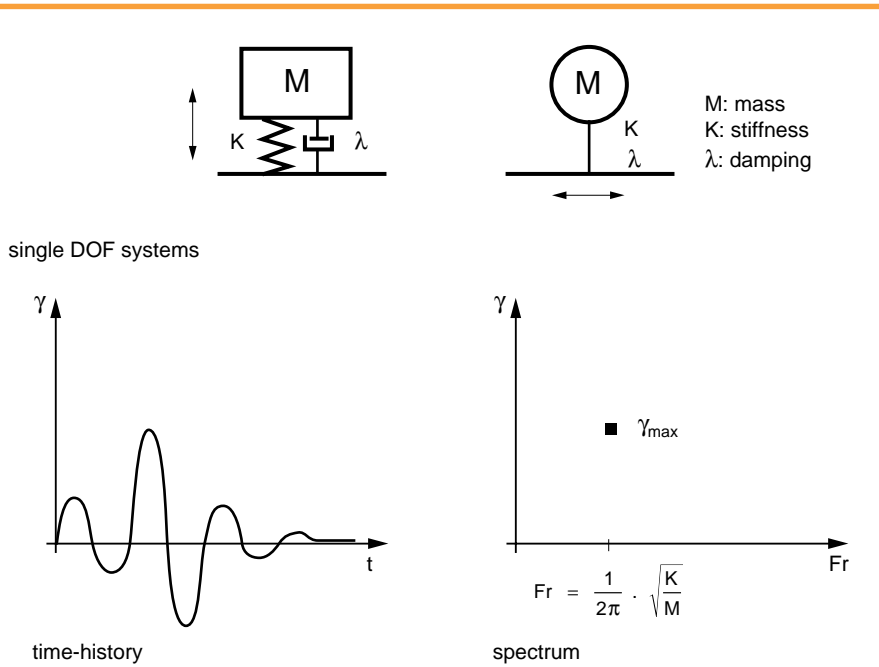

fig. 7: application of seismic excitation (time-history, see fig. 6) to 1st single DOF, induces accelerations. The maximum value ( $\gamma_{max}$ ) is by definition one point on the response spectrum of the seismic system.

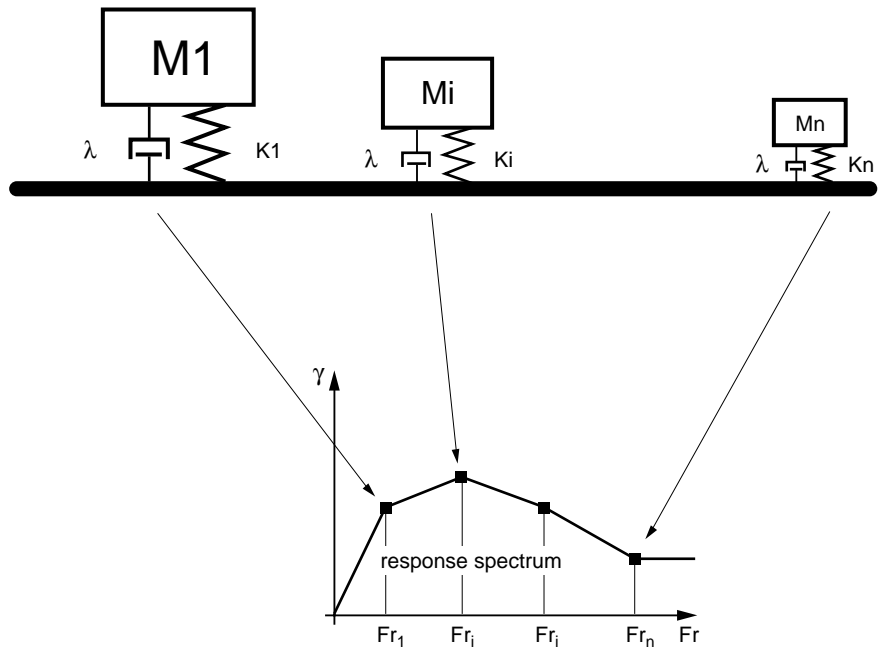

fig.8: construction of seismic response spectrum (various K/M with λ constant).



which is likely to provoke the maximum effect on a given site. For the dimensioning of works or equipment it is the SSE which is taken into account: the SSE is equivalent to the MHEL plus one degree on the MSK scale (modified Mercalli scale).

### Basic response spectrum

Macro seismic data which correspond to the above definitions are not sufficient for the engineer who has to design a building or an equipment. He will also require the representative response spectrum of the site concerned, which is established by using instrumental seismic data.

A seismotheque has been created (readings taken in regions of considerable seismic activity), which corresponds to a scale of magnitudes, seismic focus depths and epicentral distances for very diverse geological contexts. This seismotheque allows the form of the response spectrum, or basic response spectrum as it is called, to be established, for a given region, with its amplitude depending on the chosen SSE.

This response spectrum defines seismic severity at ground level. The seismic severity for the storey where the equipment will be installed still has to be evaluated.

### Dimensioning spectrum

Seismic withstand specifications are widely presented in the form of a family of response spectra for each storey. These are calculated by taking the building's transfer impedance into account. An example is given in figure 10.

### reading the response spectrum applicable to a piece of equipment

The benefit of the response spectrum is that it visualises the extreme acceleration effects (or displacement effects) provoked by excitation on a single DOF system.

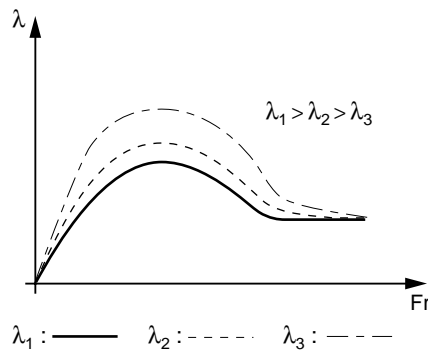

fig. 9: family of response spectra obtained for different dampings during the same earthquake.

### Acceleration / velocity / displacement conversion

Response spectra are often represented in an acceleration/frequency system of coordinates but are sometimes represented in the velocity/frequency system of coordinates. For low damping of equipment studied ( $\leq 10\%$ ), the response spectra measured in terms of velocity and the relative displacement can both be deduced from acceleration spectra by applying the following equations to each frequency:

$$V_{\max} = \frac{\gamma_{\max}}{2 \pi f}; D_{\max} = \frac{\gamma_{\max}}{(2 \pi f)^2}$$

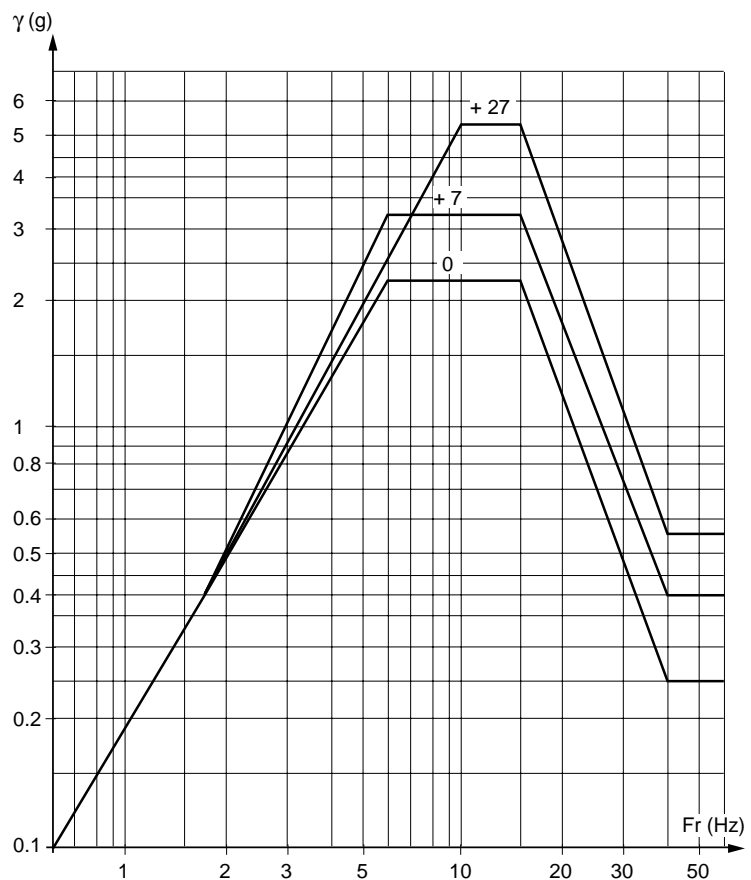

fig. 10: dimensioning spectrum, according to floor levels (in metres) for an industrial site. This is a spectrum for a damping of 2 %.

In fact, everything occurs as if sinusoidal quantities were involved, with

$$V = \int \gamma(t) dt \quad \text{et} \quad d = \iint \gamma(t) dt$$

With log/log coordinates the response spectrum can be read along acceleration, velocity or displacement axes, (see fig. 11).

**Maximum floor acceleration and displacement**

Since the energy from the seismic excitation is limited to a frequency of 35 Hz, the points on the spectrum situated above this frequency represent the behaviour of a «rigid» oscillator (very high K/M), which remains dimensionally stable under seismic excitation.

The relative displacement of the mass in relation to the support is therefore zero and its acceleration is equivalent to the support's acceleration (see fig. 12 a).

The high frequency asymptotic curve on the response spectrum (Fr ≥ 35 Hz) corresponds therefore to the maximum floor acceleration (see right-hand part of figure 13).

**Remark:**

For the right hand part of the spectrum (which corresponds to the «infinite» relative frequency), experts use the abbreviation ZPA (Zero Period Acceleration) to establish the acceleration level.

In the same way, the lowest frequencies on the spectrum represent the behaviour of an oscillator which remains «infinitely supple» under seismic excitation.

The relative displacement of this type of oscillator equates to the displacement of the support (see fig. 12 b).

At low frequency the asymptotic curve on the response spectrum, when represented in log/log scales, corresponds to the ground displacement zone (see left-hand part of figure 13).

**Maximum acceleration and displacement of oscillator**

Between 1 and 35 Hz (central part of figure 13) the oscillator accelerations and displacements are generally higher than the floor equivalents.

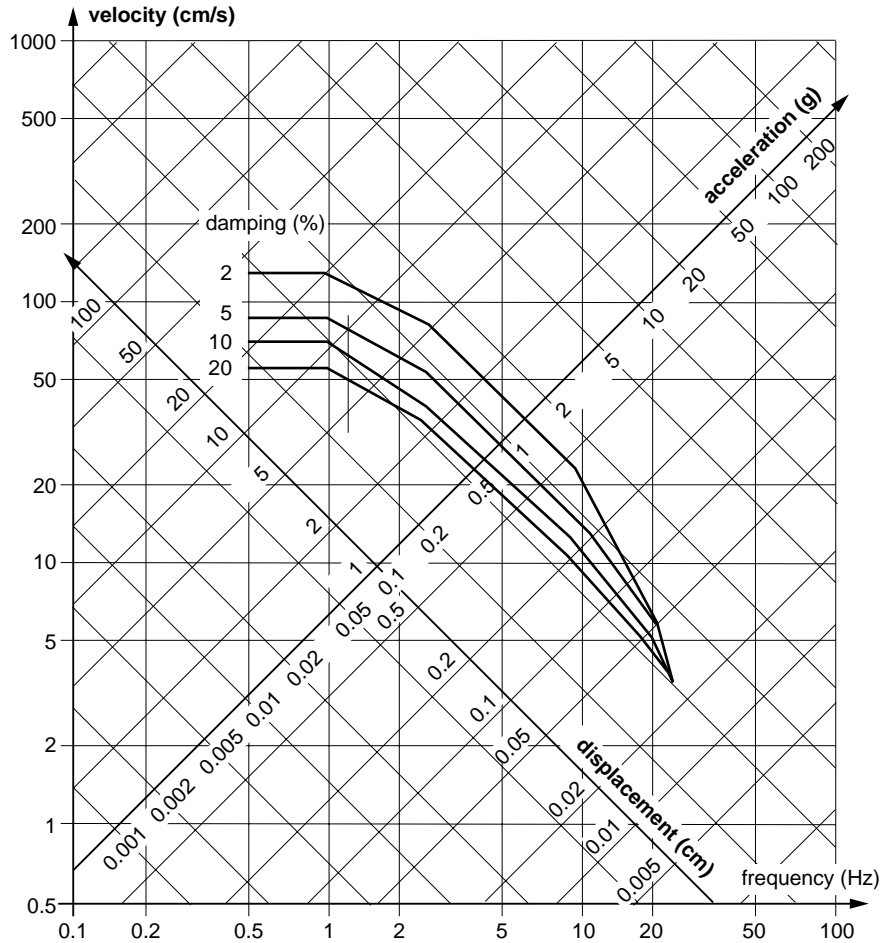
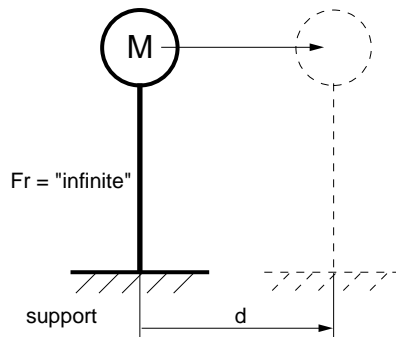

fig. 11: sample response spectrum which can be read along acceleration, velocity and displacement axes.

a) with a «very high» K/M ratio the «system» does not deform (the mass adopts the ground displacement)  
 $\gamma = \gamma_{sol}$



b) with a «very low» K/M ratio the «system» deforms (the mass remains immobile)  
 $\gamma = 0$

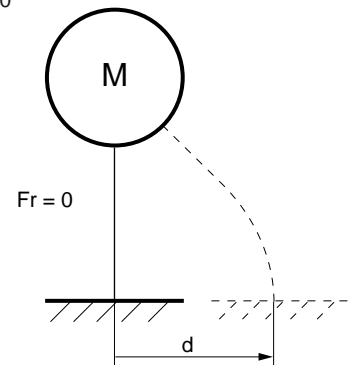

fig. 12: response on a single DOF system for maximum values of its resonance frequency.

Maximum acceleration and displacement, as well as the corresponding resonance frequencies are read directly off the spectrum (see fig. 13 - readings along axes  $\gamma$  and  $d$ ).

Where the dynamic characteristics of an equipment are not known, it is assumed that the equipment comprises a certain number of single DOF oscillators.

The majorant values of the maximum displacement and maximum acceleration it will be subjected to during the earthquake, can be ascertained from the response spectrum.

### Choice of damping for equipment

The damping factor taken into account in the response spectrum analysis is supposed to represent the global damping for the equipment concerned.

If the equipment comprises components with different dampings, then it is normal practice to work with the smallest, with regard to the choice of response spectrum; this leads to an increase in the stresses.

The table in figure 14 shows, indicatively, the values commonly agreed upon in terms of the percentage of the equipment's maximum stress. Since seismic specification is generally expressed in terms of a family of response spectrum which corresponds to the different damping (2 %, 5 %, 10 %, etc.); the equipment designer can then effectuate an interpolation.

### Benefits of the response spectrum

The information provided on an examination of the response spectrum is much more useful to an equipment designer than that provided by the temporal representation of an earthquake. In fact, while the time-history provides the maximum floor acceleration, the response spectrum provides a maximum amount of information, notably, the following maximum values:

- maximum floor acceleration,
- maximum floor displacement,
- maximum acceleration for a part of the equipment,
- maximum displacement for a part of the equipment.

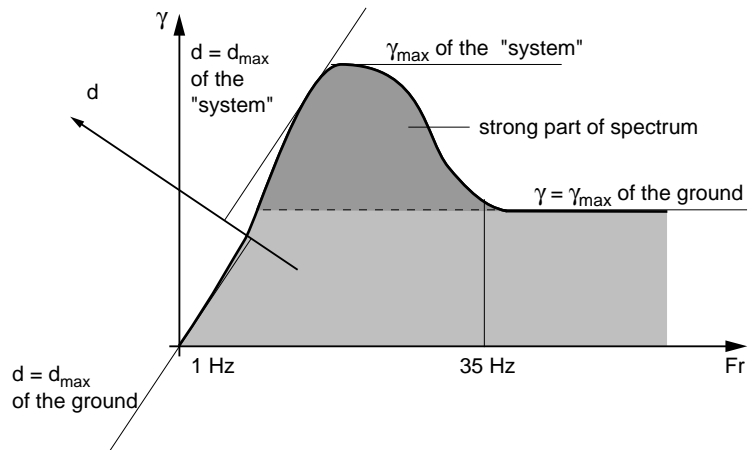

fig. 13: response spectrum reading (in log/log scale it is possible to read the values which characterize the acceleration and displacement).

type of structure	damping in %	
	for 50 % of the maximum yield	for 100 % of the maximum yield
welded steel structures	2	4
bolted steel structures	4	7
reinforced concrete structures	4	7
cabinet	2	5
rack	2	5

fig. 14: commonly agreed upon dampings for diverse structures according to the yield of the stress (deflection or traction/compression).

## 2. dynamic behaviour of structures

Today, the study of the dynamic behaviour of structures constitutes an essential stage in the design of all industrial equipment. At this stage, it is appropriate to present the main concepts which govern a structure's response to seismic excitation. Refer to the bibliography for further reading.

### brief summary of single degree of freedom oscillator

The single DOF oscillator, constitutes one of the basic principles in dynamic analysis of structures. In fact, the dynamic behaviour of an elastic structure amounts to the behaviour of a certain number of basic oscillators. Furthermore, it is often the case that the inclusion of the first mode of resonance for a given structure suffices for dimensioning; this equates to studying a basic equivalent oscillator (two types are shown in figure 7).

The basic oscillator is characterized by its resonance frequency or natural frequency, and by its damping. The resonance frequency corresponds to the free movement of the oscillator, with no external force. In other words, it concerns the frequency of the oscillator's displacement when it is distanced from its rest position (free oscillation test) or on impulse. When the oscillator is «excited» to this frequency, «resonance» is produced, that is to say, the movement is amplified. This amplification is inversely proportional to the damping of the oscillator. Resonance frequency and damping are sufficient for calculating this system's response under any excitation, and in particular, excitation by support displacement which constitutes the earthquake.

### elastic structures (with N degrees of freedom)

#### Resonance frequencies and modal shapes

Generally speaking an elastic structure (for example a whip antenna, a beam gantry), is characterized by a multitude of resonance frequencies (theoretically infinite in number) which correspond to the resonance modes or characteristic modes, (these structures have N

degrees of freedom), (see fig. 15).

Each of these resonances is accompanied by a specific deformation of the structure termed the modal shape. For each resonance frequency, the structure deforms and oscillates on both sides from its rest position (the points of the structure evolve in phase and in antiphase and produce nodes and antinodes in the modal shape). The higher the mode, the more complex the corresponding modal

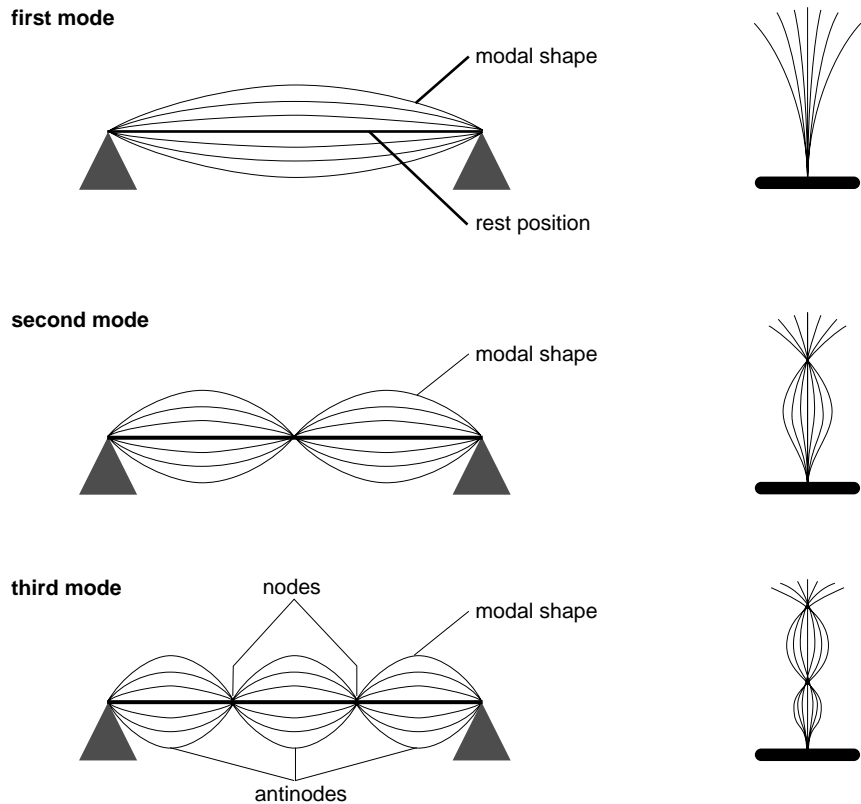

fig. 15: modal base: primary resonance modes of two basic structures.

shape becomes, with an increasing number of nodes and antinodes. The dynamic behaviour of structures, comprising  $N$  basic structures with one degree of freedom, (see fig. 16), is usually determined by using what is known as the modal analysis of the structure, which consists of tracing the resonance frequencies and modal shapes on the frequency band that corresponds to the earthquake. This establishes a work basis comprising the structure's  $N$  primary modes, called the modal base, in which the initial problem will be reduced to the study and combination of  **$N$  single DOF systems** (see fig. 16 right).

**Frequential and spatial adaptation**

An elastic structure's resonance is obtained on two conditions:

- that the excitation frequency coincides with the structure's resonance frequency. Here it is a matter of **frequential appropriation** (only condition required for systems with 1 DOF),
- that the excitation direction as well as its localization are coherent with the corresponding modal shape. If puntual, the excitation must not act on one of the structure's nodes, and is all the

more efficient when it acts on an antinode in a direction parallel to the antinode displacement.

Where multiple excitations occur, they also have to respect the phase relationships of the modal shape (see fig. 17).

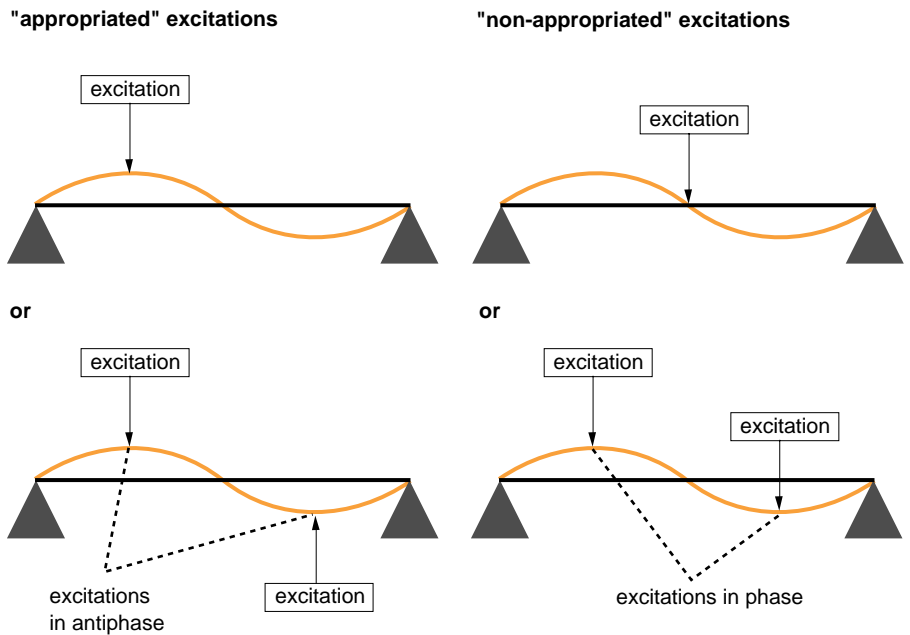
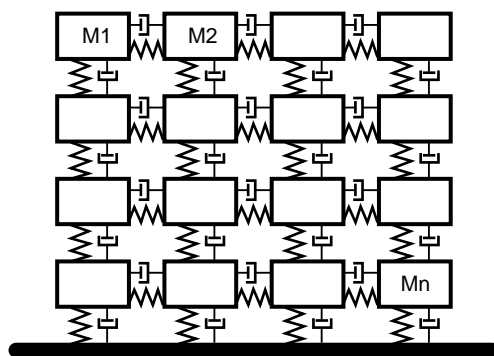

fig. 17: examples of spatial appropriation for puntual excitations.

**structure with  $N$  degrees of freedom**



**in the modal base**

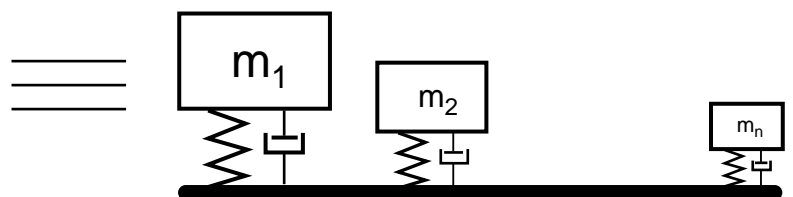

fig. 16: complex structure with  $N$  degrees of freedom.

This second condition applies to **spatial appropriation**, which is characterized by the coefficient known as the modal accommodation ratio:  $t$ .

**Response under support displacement excitation**

When a structure undergoes floor acceleration  $\gamma(t)$  (ie. a earthquake) everything happens, supposing that the floor is fixed, as if each element of mass  $m$  of the stucture was subject to an inertia load

$$F_i = - m_i \gamma(t).$$

These  $F_i$  loads are in phase according to the above equation; which reveals the importance of the notion of spatial appropriation in the response of each of the structure's modes. This particularity of seismic excitation results in primary mode responses being favoured, because these modes show, **for a given direction**, a minimum of vibration nodes. In other words, most of the points of the structure move in phase and verifie the spatial appropriation (see fig. 18).

From an analytical point of view, the structure's response takes the form of a linear combination of the modal shape of  $D_i$  of each mode:

$$\vec{D} = \sum_{i=1}^n y_i(t) \vec{D}_i$$

with response spectra and modal shapes for a structure, the  $y_i$  coefficients are obtained by:

$$y_i = \gamma_i t_i$$

where  $\gamma_i$  = spectrum acceleration for  $F_i$ , and  $t_i$  = modal appropriation ratio which corresponds to the  $D_i$  mode.

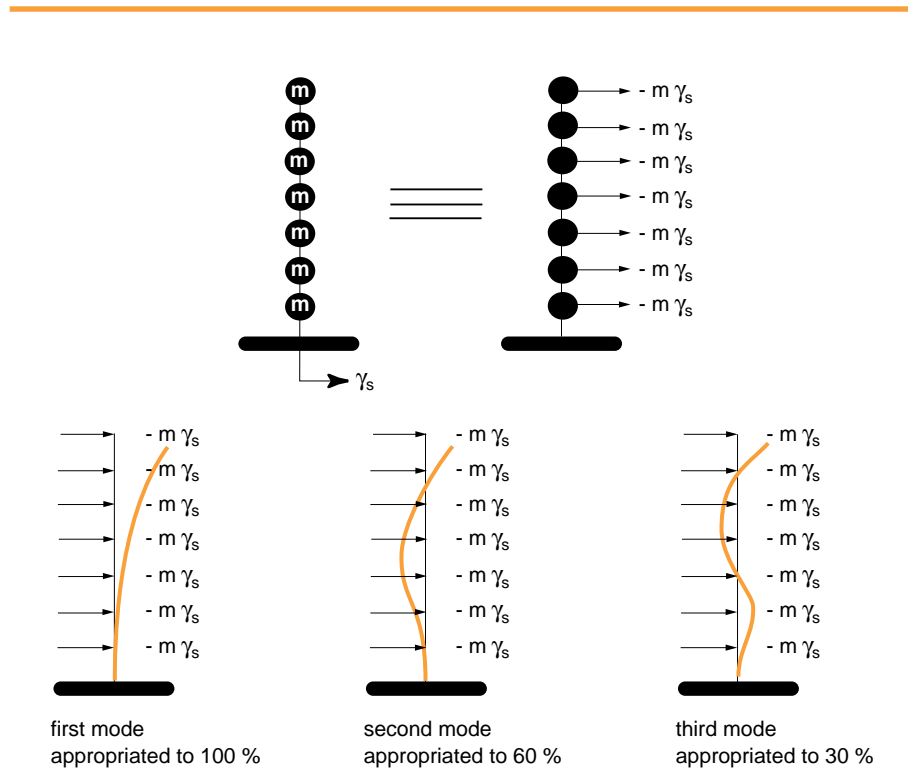

fig. 18: equivalence between support displacement and punctual loads. Example of spatial appropriation of the first three modes of a clamped-free beam.

The summation of the  $D_i$  modal shapes with the  $y_i$  coefficients gives the maximum displacement (or acceleration) for the different points of the structure during the seism (see fig. 19).

However, the response spectrum does not show the exact time at which the

maxima occur for each mode. The arithmetic summation in absolute value leads to a pessimistic evaluation, and is as a result only used when modes present neighbouring frequencies (10%). A quadratic summation is therefore more appropriate for modes which do not present neighbouring frequencies.

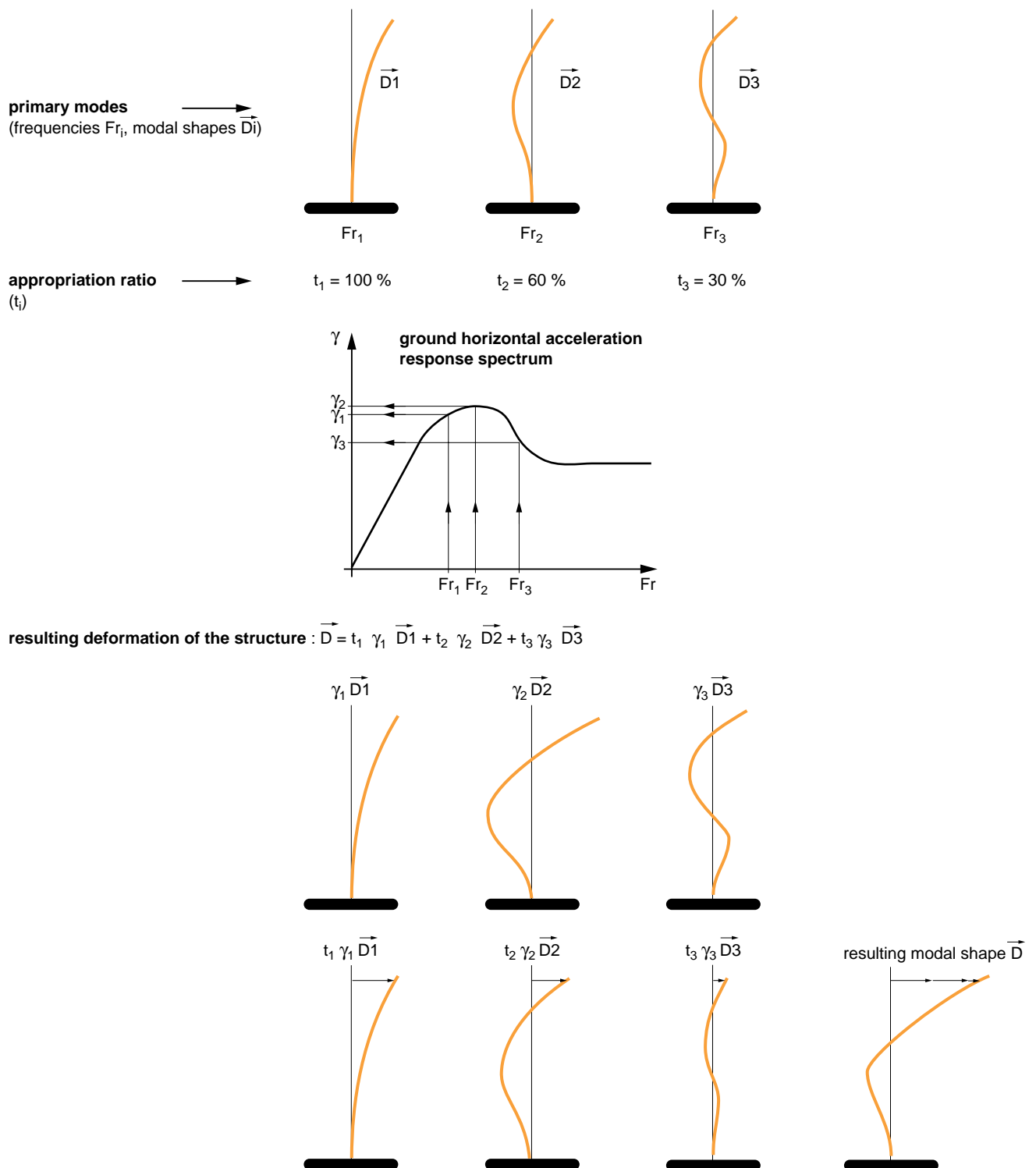

fig. 19: to obtain the deformation for all the points of a structure, when the appropriation ratios and the corresponding  $\gamma_{max}$  are known, a geometric sum suffices.

## 3. equipment design

### defining objectives

If the design is to take the seismic stresses fully into account, then the degree of safety it has to assure during and after the earthquake must be known.

The demands made on the behaviour of equipment exposed to earthquakes are:

- stability (equipment must not become projectile),
- integrity (equipment must conserve its initial geometry),
- functioning (equipment must assure either complete, partial or degraded functioning).

While the designer is only concerned with the equipment's mechanical withstand capability as far as the first two demands are concerned, the procedure is more complex for the third demand, since the different functional aspects have to be taken into account. This is usually the case for electrotechnical equipment for which operating conditions, in the eventuality of an earthquake, are usually similar to nominal operating conditions. The characteristics of the structure which transfer the excitations must therefore be defined according to the functional cells' fragility threshold.

See fig. 20 for vocabulary.

### Mechanical withstand capability

In order to check an equipment's mechanical withstand capability, it must be ensured that there is good dimensioning of the ground supports and that the structure's safe stresses are not exceeded. These dimensioning criteria are entirely dependant on the position of the first resonance frequencies envisaged for the seismic solicitations.

As far as electrotechnical equipment is concerned, the nature of the transfer of ground seismic solicitation to functional cells, must be taken into account at the design stage. The fragility threshold of functional devices

(level of acceleration at which the equipment no longer performs its function) has to be determined beforehand.

### Functional withstand capability

The vibratory stresses to which the functional devices will be subjected must be evaluated, and there must be assurance that they would function correctly when put under these stresses, or that their availability is unaffected.

There are two possibilities:

- the functional device is a protective or monitoring device produced in series: the equipment generally undergoes a vibratory environment qualification, the results of which can be exploited in order for the seismic withstand capabilities to be evaluated. Otherwise, the equipment's behaviour on the seismic excitation range (0-40 Hz) must be studied,
- the functional device is a special device, in which case an evaluation by test is necessary.

In certain cases, an analysis of the tests carried out on an analogous equipment, can provide the technical elements which will reveal the functional withstand capabilities of an apparatus.

### design principles

It is essential that the transfer notion figures in the design. In fact, electrical equipment generally comprise a frame or skeleton (structure) which, in the eventuality of an earthquake, transmits more or less faithfully the floor vibrations towards the functional devices.

### Response spectrum and dynamic characteristics of the structure

The response spectrum, which represents the floor movements, allows:

- on the one hand, the excitation severity the structure is likely to undergo to be determined (in terms of acceleration and displacement (see end of first chapter)),

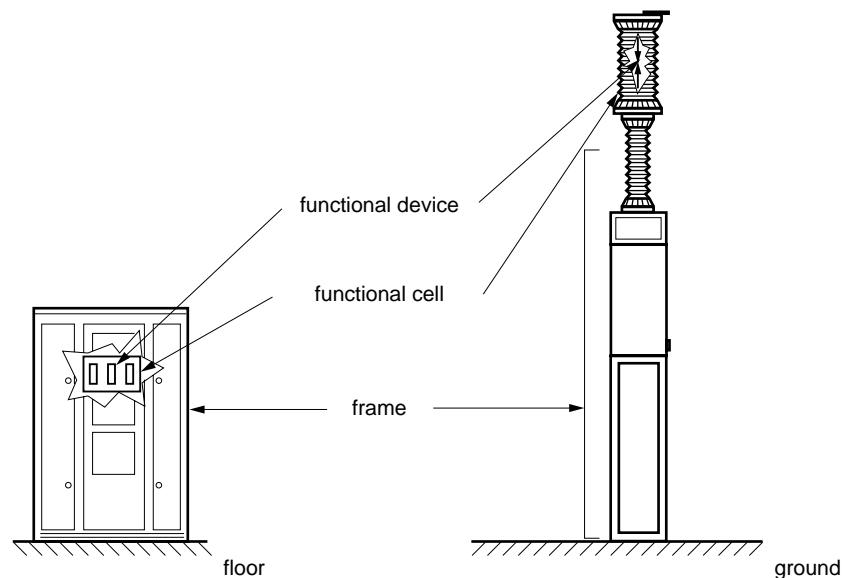

fig. 20: definition of the terms used for an equipment (LV cabinet, HV circuit-breaker).



■ and on the other hand, to determine whether or not the structure will amplify the seism, in view of the position of the resonance frequencies with respect to the strong part of the response spectrum.

It is therefore imperative that the designer knows the structure's primary resonance frequencies; these can be estimated by analysis, tests or by analogy, remembering that a spectrum consists of two zones (see fig. 21):

■ the right hand side of the spectrum, during which the equipment has the same accelerations as the ground without amplification.

When the equipment's resonance frequencies are in this zone, the equipment's mechanical behaviour is termed «static equivalent» or «pseudo static». Evaluation of maximum stresses is obtained by successively applying the maximum ground acceleration (ZPA or Zero Period Acceleration) to the masses concerned according to the three spatial directions.

■ the strong part of the spectrum, during which the structure amplifies the accelerations by its resonances, which leads to increased forces and stresses than was previously the case. In this zone, the equipment's mechanical behaviour is dynamic and, as a result, it is necessary to know the frequencies and modal shapes and to combine them in order to evaluate the maximum possible damage that the equipment might incur.

The process therefore consists in:

- characterizing the natural vibrational modes ( $F_r$ ,  $D_i$ ),
- determining the modal responses,
- superimposing the modal responses,
- deducing the forces and stresses induced.

#### State of the art seismic design

Applying the above procedure will obviously avoid the equipment having resonance frequencies in the strong part of the response spectrum. Where possible, the designer should endeavour to limit the equipment's dimensions and in particular its height (small dimensions favour increased frequencies).

This being the case, the most widely used solution is the **stiffening** of the structure to discard the first resonance frequencies higher than the seismic excitation range, or at the very least higher than the strong part of the response spectrum. In any case, it is sensible to avoid resonance modes situated in the 0-10 Hz, or indeed 0-15 Hz frequency band, in order to increase safety.

Putting these basic concepts into practice does however have to fall in line with restrictions imposed by the equipment's cost, dimensions and functioning.

When an equipment is obviously too fragile and can not be sufficiently stiffened, it is possible to **isolate** the equipment from the ground by interposing a suspension stage. To be effective, the suspension must however possess the characteristics required by very high-performance damping plugs (suppleness and deflection). So as to achieve accelerations for the equipment of a lower amplitude than the ground accelerations, the suspension should confer very low resonance (suspension) frequencies, (in the order of 1 Hz) to the suspended equipment, and should accept displacements greater than 40 cm.

Such characteristics cannot of course be obtained with classical plugs and the resulting displacements are not free from inconveniences for supported equipment (respecting positioning, external connections, dielectric distances). This method is not therefore widely used.

#### On switchgear in cabinets

When for example a cabinet houses diverse equipment, it is necessary to do carry out both a mechanical transfer study and an evaluation of the robustness of the equipment in question, with a view to establishing the compatibility between the aptitudes of the cabinet and the limits of the switchgear's functional withstand capability to the vibratory environment. To limit the amplifications of the cabinet's movements, and as a result the transfer, it is necessary to have rigid cabinet frames (reinforced or braced). The required degree of rigidity is in accordance with the robustness of the switchgear.

The usual recommendations include:

■ cabinet construction: assemblies which are bolted or welded together are preferable to those which are riveted together which can work loose and generate impacts which are harmful to the switchgear,

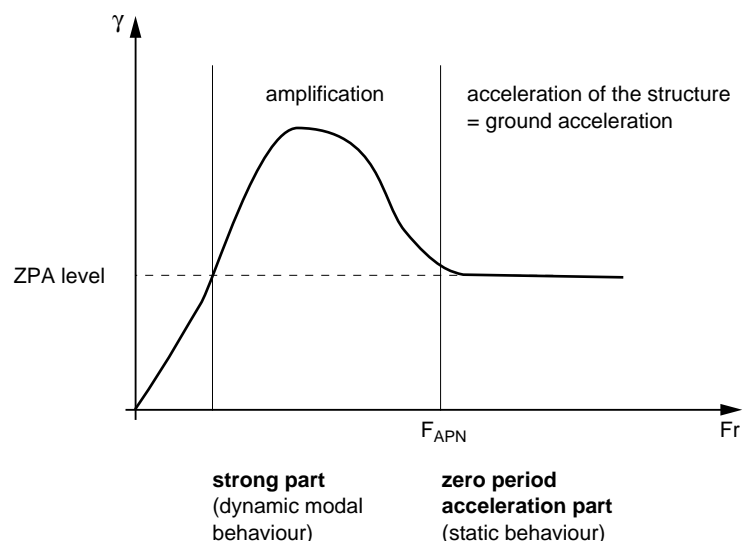

fig. 21: resonance frequencies in the strong part of the response spectrum are to be avoided.

■ mounting of the cabinet: the ideal solution consists in bolting the cabinet to the ground and the wall, with fixings which must be dimensioned so as to resist the loads resulting from seismic acceleration,

■ disposition of the cabinet: if the cabinet is only mounted to the ground, it is better for the heavy masses to be arranged at the bottom of the cabinet; the same applies to fragile devices,

■ mounting of devices: rigid fixings are preferable; otherwise, it is wise to be wary of local resonance modes, and to the different movements during the seism,

■ circuit boards: avoid boards which are too large or too full, heavy components; provide stiffeners if necessary,

■ cabling: so as to avoid inertia loads, flange the cable layer as close as possible to the connectors.

## simulation by analysis at design stage

Numerical analysis for a structure's dynamic behaviour generally uses the finite elements method. This numerical technique allows the mechanical behaviour of a structure, subjected to dynamic solicitations, similar to those generated by an earthquake, to be predicted. This technique is particularly well suited to the design stage, when the structure only exists in the form of definition or utilisation plan, and can still be modified. It provides essential data for the designers with regard to stresses, anchorage loads and the deformations produced by the seismic excitation.

### Principle

The principle behind this method is to construct a simplified model of the equipment, by using a certain number of «finite elements» (beams, plates, volumes) which represent the structure, as well as concentrated masses representing the functional devices. «Meshing» uses the structure's geometric data (profile, thickness, profile inertia) and the equipment's physical characteristics (Young's modulus, density) (see fig. 22 for an example).

The detail of the meshing is not essential in order to access fundamental modes, but care must be taken to respect the distribution of the principle elements of stiffness and mass. However, when the stresses are being calculated the meshing must be sufficient.

The computing program then determines, on a seismic excitation range (0-40 Hz), the resonance

frequencies and modal shapes associated to the model, as well as the modal participation factors: this is modal analysis.

The table in figure 23 gives the elements of modal analysis for a transformer; these reveal the LV insulator to be a sensitive element, but that the conservator is even more so, because its second resonance mode has a frequency of 11 Hz (which is likely to

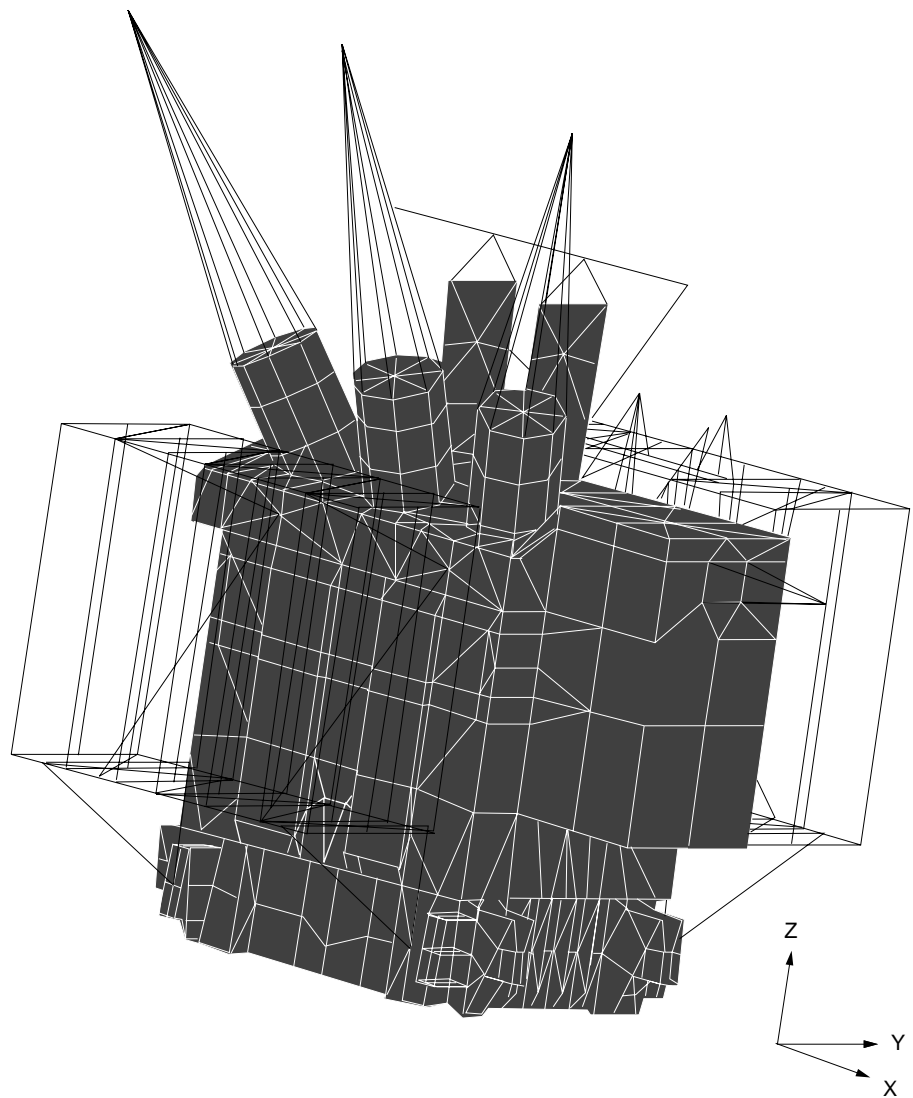

fig. 22: meshing of «finite elements» of a EHV transformer (2,000 elements and 1,500 nodes).

appear in the strong part of the seismic excitation response spectrum).

The next stage consists of simulating the equipment's response under seismic excitation and thus obtaining the displacements, stresses and loads on the supports.

Two methods can be used according to the position of the structure's resonance frequencies with regard to the strong part of the response spectrum:

■ pseudostatic analysis

(The resonance frequencies appear above the strong part of the response spectrum).

If this is the case, then the analysis is static, and the model is subjected to maximum ground acceleration for every direction.

■ superposition method analysis

(Certain resonance frequencies are in the strong part of the response spectrum).

In this case the model's response for a given direction is obtained by multiplying the modal shape for each mode (Di) by its modal participation factor and by the acceleration read at this mode's frequency on the response spectrum. The responses of the different modes are then combined in order to obtain a global response for a given direction.

It must be recalled that the model's response spectrum does, by definition, include damping: it is therefore necessary to use a response spectrum which corresponds to the damping of the structure studied, even a less favourable one, that is to say the weaker one.

The last stage involves ensuring that the maximum values of displacements, stresses and loads on connections are acceptable, that is to say compatible with the structure's mechanical characteristics. There are combination rules for seismic and static stresses (own weight, snow, wind, pressure, traction loads). Moreover, the spatial distribution of accelerations will make it possible to check the functional withstand

capability of the switchgear and the connected instruments, either by using specific tests or by making comparisons with tests which have already been carried out.

**Limitations of the «finite elements» method**

When test models with finite elements are used, divergence is obviously going to occur between the calculated and actual resonance modes of the installed equipment. This is mainly due to the approximations made as far as the limit conditions (how structure is mounted to the ground), internal connections, non linearities, as well as the different simplifications inherent in test models are concerned. Generally speaking only the primary vibrational mode calculation which is acceptable.

However, given the broad band nature of seismic excitation, the evaluation of stresses calculated by response spectrum tolerates an error as to the resonance frequencies exact position. This explains why it still makes sense to use this method at the design stage.

**Modal tuning**

As soon as the equipment prototype is ready, it is possible to correct the finite elements model, by carrying out a «tuning» according to the measurement data. Different experimental techniques enable the structure's actual dynamic characteristics to be obtained, by using the «tuning» software, and to make the necessary modifications to the finite elements model, so that it might provide a closer representation of reality.

mode No	frequency (Hz)	modal participation factor	element concerned
1	8.7	4	conservator
2	11	232	conservator
3	12.7	14	radiator
4	13.2	34	all auxiliary parts
5	13.8	5	heat exchanger
6	15.9	24	conservator
7	17.2	11	heat exchanger
8	19	105	all auxiliary parts
9	19.3	51	all auxiliary parts
10	21.2	24	heat exchanger
11	22.9	18	conservator
12	23.1	7	heat exchanger
13	24.1	4	surge arrester
14	24.4	47	surge arrester
15	24.6	42	surge arrester
16	24.8	3	surge arrester
17	24.9	0,2	radiator
18	25.5	33	surge arrester
19	26	96	radiator
20	26.5	6	heat exchanger
21	26.6	25	radiator
22	29.3	115	LV insulator
23	30.3	354	LV insulator
24	30.5	11	LV insulator
25	31.6	2	LV insulator

fig. 23 : résultat du calcul modal pour les divers éléments du transformateur de la fig. 22.

## 4. qualification by simulation or test

### introduction

To qualify means proving the equipment's withstand capability under identified or normalized stresses. There are two ways of realizing seismic qualification:

- the first involves effectuating «real size» tests on the equipment;
- the second uses «finite element» test models which can be combined with a certain amount of experimental data. The latter is becoming more and more important in the qualification process, particularly as far as mechanical withstand capability is concerned. But today it is still tricky to take account of the functional aspect by using a test model.

#### Qualification by test is used:

- for equipment with dimensions which lend themselves to the vibration testing machine,
- for specific equipment (unitary, small series),
- if the functional aspect is determining (complex or high level of safety).

#### Qualification by numerical analysis is used if:

- the dimensions of the equipment are incompatible with the testing machines (as is the case for large transformers),
- a device has already been tested under other seismic conditions,
- the device is a modified version of a qualified device,
- the functioning of the equipment is not requisite during the earthquake.

#### Combined qualification by numerical analysis and experimental modal tuning is used:

- for large series equipment,
- when standards or operators permit this kind of justification (knowledge of functional data).

In fact, numerical analysis often precede «real size» tests. This maximizes chances of correctly

effectuating the qualification tests successfully first time round.

We will now:

- illustrate by means of two examples: combined qualification and qualification by «real size» tests preceded by a design test model,
- develop the methodology of qualification by test.

### combined qualification (numerical analysis and experimental tuning)

The method which combines both analysis and tests involves:

- creating a mathematical model,
- gathering in the data from partial tests (modal experimental analysis) carried out on the prototype, concerning the device's dynamic behaviour (damping, resonance frequencies, modal shapes),
- tuning the mathematical model with the preceding data.

The analysis model then allows the mechanical withstand capability to be evaluated under accumulated seismic solicitations and service stresses. The functional withstand capability involves checking that the equipment is not badly affected by the deformations and accelerations delivered by the analysis.

The following example shows the method which combines both tests and calculation used to define seismic resistance of HV circuit-breaker.

#### Seismic qualification of a HV circuit-breaker

(see fig. 24)

- first stage: numerical analysis of circuit-breaker.

The model is made out of finite elements: (beam-gantries, plates and shells for the insulators), the model comprises 2,670 elements and 3,200 nodes,

- second stage: experimental modal analysis (see fig. 25 and 26). This analysis is carried out on the prototype. It consists in acquiring the transfer functions between a point of excitation (generated force) and the response points (measured accelerations), then identifying the actual modes of the structure (resonance frequencies and associated modal shapes),

- third stage: tuning of finite element model.

Here the parameters of the finite element model are readjusted (finesse of meshing, physical parameters: YOUNG's modulus, density, limit conditions) so that the model's dynamic characteristics can be made to reflect reality as closely as possible,

- fourth stage: measuring the damping coefficient.



fig. 24: Merlin Gerin circuit-breaker designed for use in HV switchgear equipment.

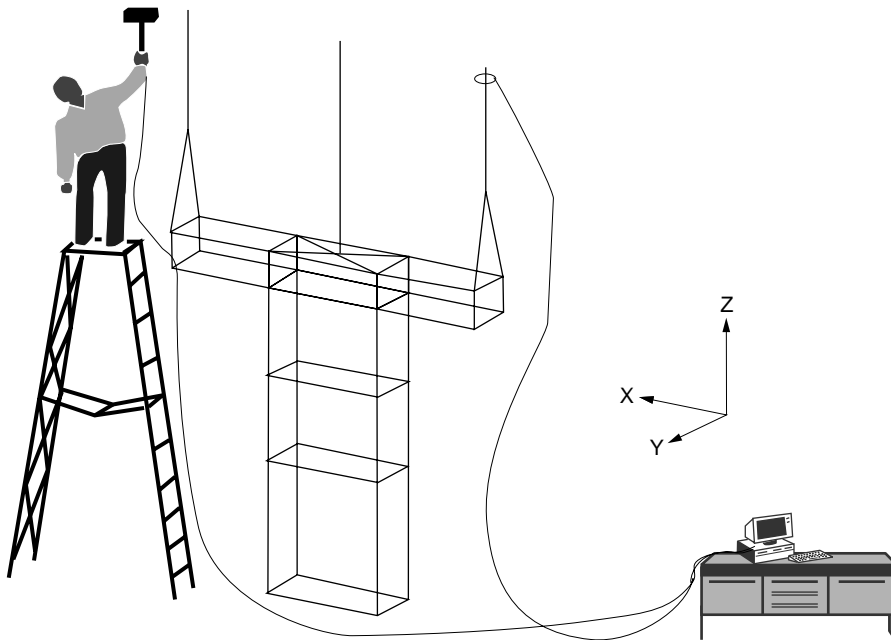

fig. 25: modal experimental analysis.

In order to calculate the circuit-breaker's response using the response spectrum method, it is necessary to know which damping to apply to the model. This is obtained by subjecting the prototype to a substantial mechanical deformation (free oscillation test) ; damping is then deduced by observing the decline in oscillations,

■ fifth stage: analysis of loads, stresses, and displacements under seismic charge.

The analysis of the response is carried out by using the response spectrum method, it makes it possible to take different earthquakes into account,

■ sixth stage: verification of the device's integrity and functioning under seismic loads.

This verification consists:

□ on the one hand, in verifying the mechanical withstand capability of the structure in terms of loads on connections and stresses in the

materials when the circuit-breaker is subjected to accumulated seismic stresses and service stresses (weight, internal pressure, static loads on the terminals, wind) (see fig. 27 page 22, stresses in the HV circuit-breaker), □ and on the other hand, in assuring that the deformations which result from the seismic sollicitation do not interfere with the functioning of the device; this final verification is carried out statically by imposing the deformation obtained from the analysis on the equipment, and by executing the different operations for which it is intended.

### qualification by «real size» tests preceded by numerical analysis

Even if the material is to undergo qualification tests, it is still of interest, in order to save time and money, to precede building and testing by a test model effectuated from plans.

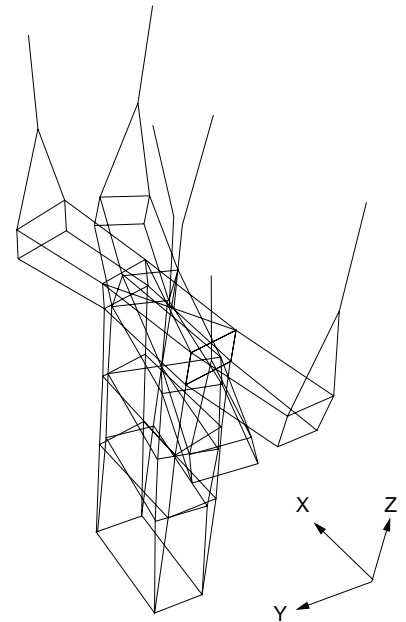

fig. 26: resulting experimental modal shape (f = 3.8 Hz).

### Qualification of control/monitoring cabinets

Control/monitoring cabinets intended for nuclear power stations are considered in the following example. This equipment is subject to strict functioning safety regulations, and, to this end, undergo «real size» tests for resistance to seismic sollicitations (see fig. 28, p. 23).

In order to be able to present an equipment with higher guarantees of good resistance for testing, a certain number of simulations and investigations are carried out at the design stage. The procedure is as follows:

■ robustness evaluation of main devices installed in the cabinet. For equipment which does not have any historical data, a maximum withstand capability test is carried out on the seismic excitation frequency range. This involves establishing the equipment's fragility threshold (if necessary live). This data is then useful for defining the desired limitation of the cabinet transfer,

■ evaluation of transfer for the cabinet's structure.

The response spectrum form, as well as the fragility threshold of the embarked equipments, indicate the desirable characteristics of the cabinet transfer. Making a numerical analysis for the cabinet aims to identify the main resonance modes in the seismic excitation frequency range (0-40 Hz). The cabinet is modelled in beam-gantry and plate elements and the equipment is represented by punctual masses and inertia.

Finite element analysis is carried out in order to estimate the levels of vibration the cabinet will communicate to the equipment situated in the interior. According to the position of the primary resonance frequencies, modifications are made (on a plan) to reduce the amplification of ground acceleration.

■ experimental verification of the cabinet's characteristics (figure 29). An experimental measurement of the primary resonance frequencies is carried out on the equipped, wired cabinet in order to ensure that the structure's actual characteristics do not differ from those provided by the analysis,

■ impact of cabinet's actual characteristics on the equipment. The impact, on the equipment's resistance during seismic tests, of the discrepancy between the cabinet's calculated dynamic characteristics and those actually measured, is evaluated by referring to the seismic excitation response spectrum.

Modifications are made if the discrepancies engender vibrational amplifications which are incompatible with the equipment's characteristics. For example, the mounting devices for fixing the equipment to the ground and/or fixing other devices will be reinforced.

## qualification by test

Qualification by test is not always plausible (equipment is too heavy or the dimensions are too big) and it is often tricky to set up. Powerful test equipment is required (vibrating tables with large displacements powered by hydraulic jacks, sophisticated control systems), and only some specialised laboratories are capable of carrying out

these tests. In addition to the laboratory performance, the following expenditure has to be taken into account:

- cost of transport,
- cost of mounting the test equipment,
- cost of replacing material if it turns out to be non operational after the test.

The procedure for carrying out qualification tests on an equipment usually features in the specifications

sheet (or in a test program), and conforms with the current standards or recommendations (IEC 68-3-3/UTE C 20420, ANSI, ENDESA, IEEE, etc.).

Several variations of the qualification procedure are possible, and they run according to:

- the information on the geoseismic context of the equipment's location,
- the equipment's complexity,

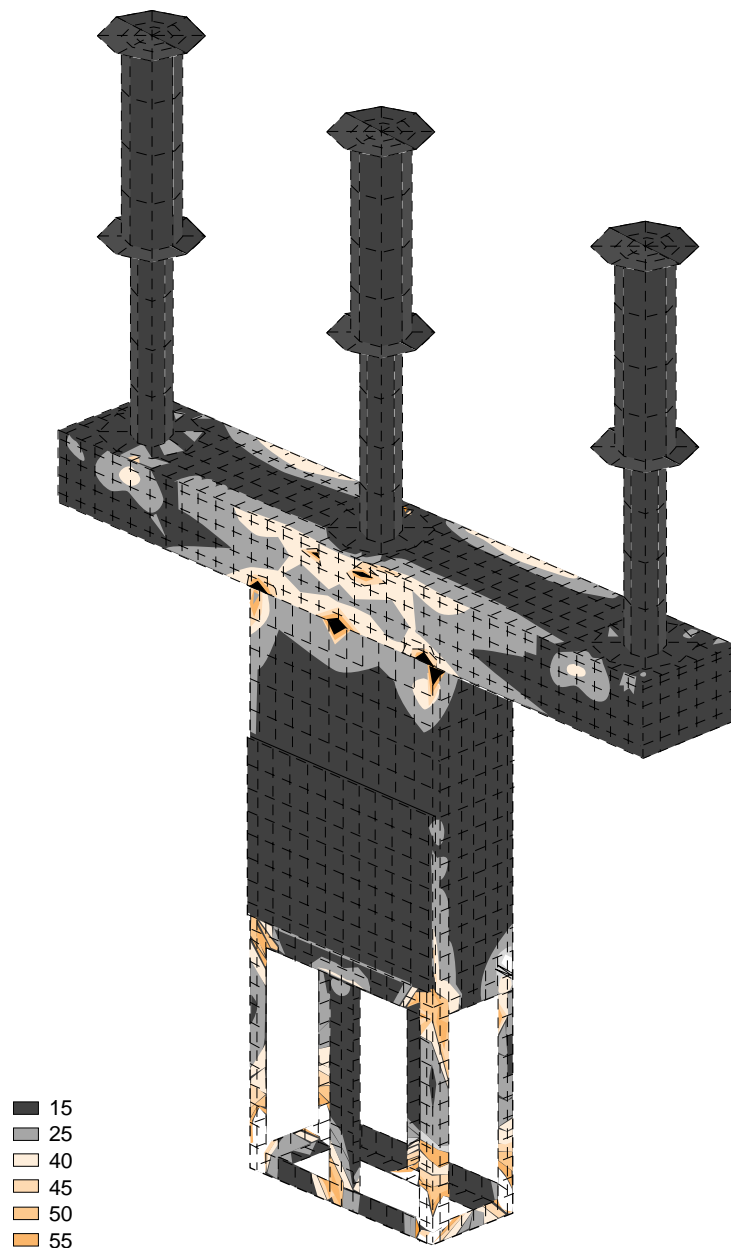

fig. 27: analysis of stresses.



- the data on the dynamic behaviour,
  - the representativeness of the equipment in tests with regard to the series,
  - the degree of safety the equipment has to ensure during an earthquake.
- Without going into too much detail, we now propose an insight into the criteria which influence the choice of modalities of a qualification by test, according to the IEC standard 68-3-3.

#### **Configuration of material being tested**

Before proceeding with seismic qualification test a certain number of modalities have to be fixed. These are notified in a particular specification which mentions, amongst other things, the arrangements to be taken into account concerning:

- choice of test specimen. Preliminary analyses are sometimes necessary in order to ensure that the chosen specimen does actually represent the worst case scenario,
- fixings and mounting. They have to be identical to those used on site,
- service conditions which have to be taken into account (mechanical or electrical),

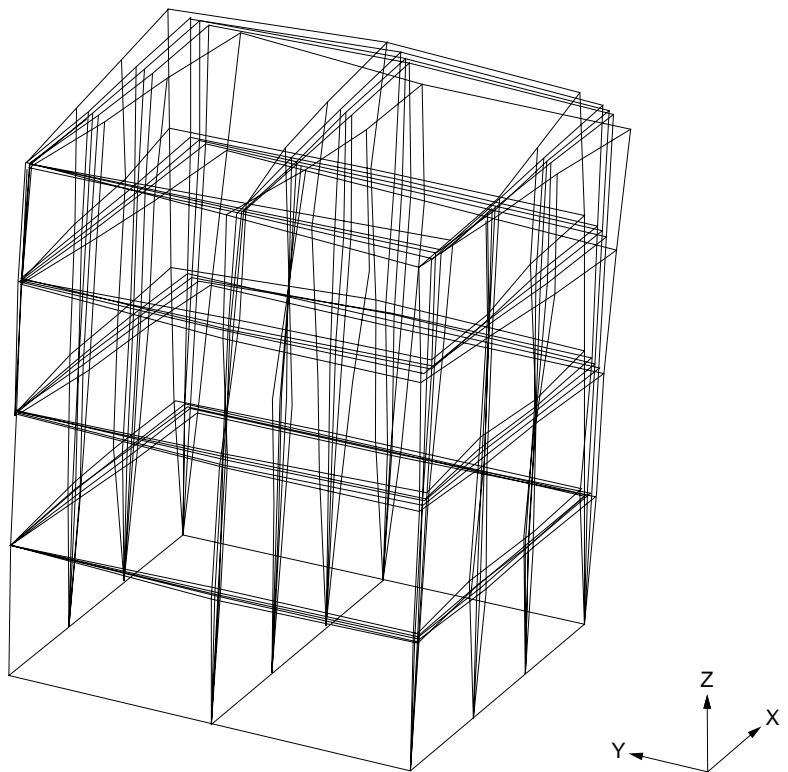

*fig. 29: modal deformation of the cabinet's frame derived from the experimentation.*

■ functioning observed during the test, as well as the methods to be used in order to check that the desired performance is maintained (measurement of the insulation or the electrical continuity, breaking capacity, animation software, etc.).

Acceptance and/or bad functioning criteria are classed according to three severities:

■ severity 0: equipment shall not show disfunctioning during and after the seismic test,

■ severity 1: equipment can function badly during the seismic test but shall remain operational after the test,

■ severity 2: equipment can function badly during the seismic test and requires intervention or an adjustment in order to regain its normal state, without replacement or repair being necessary.

#### **Choice of test severity level**

Two classes have been provided according to the availability and/or the exactitude of the seismic characteristics definition of the environment and the equipment.

■ **general** seismic class: in this case the acceleration to which the equipment will be subjected is normalized (several performance levels are usually proposed by the standard),

■ **specific** seismic class: this concerns equipment for which the considered seismic movement is the result of a seismological study (MHLE). It also takes the geographical implantation characteristics into account, in addition to those of the building or support structures. This is generally the case

for electrotechnical equipment, particularly for nuclear power stations, where the acceleration to which the equipment is subjected will be specified in the response spectrum.

#### **Different types of tests**

Different methods are used in order to recreate the seismic environment on a vibrating table. They differ in the number of directions in which are excited simultaneously (single axis, multi-axis), and in the way in which the seismic waves are recreated by test methods.

##### **■ single axis, multi-axis test.**

The seismic ground movement is produced simultaneously in all directions and, in order to simulate this exactly, triaxial tables are required, whereas normal testing permits at best biaxial tests (two excited simultaneously axes).

Where no accuracy is available concerning the equipment's seismic behaviour, the biaxial test is recommended. It requires an installation which will permit simultaneous excitation with independent waves according to two of the equipment's preferred axes; the test response spectrum must be at least equivalent to the required response spectrum. In order to effectuate testing according along the 3rd axis, it is sufficient to turn the equipment through 90° around a vertical axis and effectuate the same test again.

Single axis testing, executed according to the three preferred axes, is justified in the following circumstances:

□ if the equipment is only subjected to an excitation which could be

considered as monoaxial, on account of its on site mounting conditions,  
□ if there is no coupling (or weak coupling) between the equipment's three preferred test axes, taken two by two.

##### **■ monofrequency and multifrequency waves.**

In general the test wave used must:

□ produce a Test Response Spectrum (TRS) which is superior or equivalent to the Required Response Spectrum (RRS) notified in the particular specification,

□ have a peak maximum acceleration amplitude value equivalent or superior to that of the RRS ground acceleration (Zero Period Acceleration (ZPA)),

□ reproduce the effects of a specified earthquake with a safety margin,

□ not include frequencies higher than 35 Hz,

□ be of a duration which is at least equivalent to that of the strong part of the earthquake; in general this is between 5 and 10 s.

The required response spectrum is generally broad band, and the use of multifrequency waves is recommended. Modern testing machines enable this kind of wave to be generated, or to be more precise, to pilot the test machine, either from a time-history provided directly by the test specification, or by synthesizing a time-history from a required response spectrum (RRS), for a duration of 20 seconds. In certain transfer cases such as those found in buildings, the response spectrum is narrow band; testing can as a result be effectuated in mono frequency waves.



## 5. conclusion

The high degree of continuity of service required for electrical distribution and control/monitoring demands that all types of environmental restrictions (mechanical, climatic, electromagnetic) are taken into account. Seismic stresses, which are particularly destructive are included here and they must be specified at the design stage of the equipment.

In order to do this it is necessary to know the severity of the maximum historical earthquake likelihood in the form of a dimensioning spectrum, or, for mass-produced equipment, to

choose the level of severity of the normalised seismic class.

Today, an equipment's mechanical withstand capability can be understood with a high degree of precision thanks to numerical analysis and finite element calculation of the stresses

Proving that the equipment remained operational during or after the earthquake, is more difficult and generally requires the numerical analysis to be combined with tests on the operational elements. The examples of qualification by numerical analysis and/or tests presented in

chapters 3 and 4, reveal the know-how of a company which, for many years has been providing countries exposed to earthquakes with equipment for nuclear power stations and other electrical equipment.

As for quality or electromagnetic **compatibility**, seismic withstand must be mastered at the design stage; if this is neglected then it is often difficult and more expensive to correct problems at a later stage. As a result, numerical analysis and powerful calculation methods are used widely in the «anti-seismic» design of electrical and electronic equipment.

## 6. bibliography

### Standards

- IEC 68-3-3 (UTE C20 420):

Guidance. Seismic test methods for equipment.

- IEC 1166: HV circuit-breakers: guide to seismic qualification.

### Merlin Gerlin Cahiers Techniques

- CT 85 (1977): Seismic withstand capabilities of electrical equipment by P. PY, J.-Y. BERTHONNIER

(presents technological solutions for HV circuit-breakers).

### Miscellaneous publications

- AFPS90 recommendations for drafting rules relative to works and installations to be realised in regions subject to seismic volumes 1 and 2.

■ Dynamic calculations of structures in a seismic zone by Alain CAPRA and Victor DAVIDOVICI.

- Revue des laboratoires d'essais, ASTE publication, n° 9, 31, 36, 39.



