



n° 169

HV industrial network design

Georges THOMASSET

Graduated as an engineer from the IEG (Grenoble Electrical Engineering Institute) in 1971.

Since then, he has been designing complex industrial networks in the framework of Merlin Gerin company's Technical Division. After having headed the "Medium Voltage public distribution and hydroelectric installations" engineering department, he has been in charge of the engineering section of the Contracting department's industrial unit since 1984.

lexicon

flicker: periodic fluctuations the light output of lamps.

HTA and HTB: categories of medium voltage defined by a French decree dated 14 November 1988.

Voltage levels are classified by different decrees, standards and other particular specifications such as those of utilities. AC voltages greater than 1000 V are defined by:

■ the French decree of 14 November 1988 which defines two categories of voltage:

HTA = $1 \text{ kV} < U \leq 50 \text{ kV}$,
HTB = $U > 50 \text{ kV}$.

■ CENELEC (European committee for electrotechnical standardisation), in a circular dated 27 July 1992, specifies:
MV = $1 \text{ kV} < U \leq 35 \text{ kV}$,
HV = $U > 35 \text{ kV}$.

■ the IEC publication sets forth the highest voltage ranges for equipment:

range A = $1 \text{ kV} < U < 52 \text{ kV}$,
range B = $52 \text{ kV} \leq U < 300 \text{ kV}$,
range C = $U \geq 300 \text{ kV}$.

A revision is pending, which will include only two ranges:

range I = $1 \text{ kV} < U \leq 245 \text{ kV}$,
range II = $U \geq 245 \text{ kV}$.

■ the French national utilities EDF now uses the classification given in the decree cited above.

network dynamic stability: the capacity of a network, which includes several synchronous machines, to return to normal operation after a sudden disturbance that has caused a temporary change (i.e. short-circuit) or permanent change (line opening) in the network configuration.

network protection plan: overall organization of electrical protection gear, including: the

protection system used, the choice of devices and device settings.

network structure: overall network arrangement, often represented in a single-line diagram, which indicates the relative arrangement (interconnections, separation of circuits, etc.) of the different sources and loads.

plant: grouping (in a location) of several energy consumers.

private network: electrical network which supplies power to one or more user sites (plants) which generally have the same owner.

utility supply: electrical network which belongs to the national or local energy distributor and serves several independent consumers.

sensitive loads: loads for which no absence of power supply is tolerated.

appendices

appendix 1: extension of an existing industrial network	hypotheses	p. 19
	approximate calculation of a current limiting reactor	p. 19
appendix 2: computerized means used for network analyses	calculation software programs	p. 20
	expert system for evaluating electrical network design quality	p. 20
appendix 3: general principle of compensation		p. 20
appendix 4: choice of the earthing system for a HV industrial network		p. 21
appendix 5: network voltage drops		p. 22
appendix 6: stages in industrial network design		p. 22
appendix 7: bibliography		p. 24

HV industrial network design

contents

1. needs and main constraints to be met	needs to be met	p. 4
	main constraints	p. 5
2. main rules of industrial network design	load survey, load and diversity factors	p. 7
	choice of voltages	p. 7
	reactive power compensation	p. 7
	backup and replacement sources	p. 7
	autonomous electrical energy production	p. 7
	division of sources	p. 7
	overall electrical diagram	p. 8
	3. validation and technical and economic optimization	choice of the earthing system
	feeder definition	p. 9
	insulation coordination analysis	p. 9
	protection system definition	p. 9
	short-circuit currents calculation	p. 10
	calculation of voltage fluctuations under normal and disturbed operating conditions	p. 11
	choice of motor starting method	p. 11
	network dynamic stability	p. 12
	synthesis	p. 13
4. choice of optimal network structure and operation	standard network structures	p. 14
	concrete example of a structure	p. 16
	choice of equipment	p. 16
	optimal operation	p. 16
5. conclusion		p. 18
appendices	see page on left	

Faced with increasingly fierce competition, industrialists must employ highly rigorous management and their production facilities must have a high level of availability.

Electrical networks supply the energy required to run the production facilities. The provision of a continuous power supply to loads is strived for from the start of the network design, in particular during preliminary choices in the single-line diagram.

Reductions in electrical installation and operating costs, together with reliable failure-free operation, are vital conditions for profitability. This technical and economic optimization calls for detailed and global preliminary analyses, which include:

- specific needs and constraints related to the type of industry,
- integration of the limits and constraints of the public distribution network,
- standards and local practices,
- particularities of the operating personnel, facilities manager and maintenance personnel.

The scope of this study is limited to the analyses involved in the design of High Voltage ("HTA" and "HTB") high power industrial installations which have the following main characteristics:

- installed capacity in the 10 MVA range,
- autonomous electrical energy production (when applicable),
- power supplied by a national transmission or distribution network (≥ 20 kV),
- private Medium Voltage distribution.

1. needs and main constraints to be met

Industrial electrical networks must supply power to all the plant loads, at optimal investment, operating and loss of production costs, taking into account:

■ the needs to be met:

- safety of people,
- safety of property,
- continuous power supply,
- network operating ease,
- minimum installation cost,
- optimization of electrical energy (cost / quality),

network changes and future extensions,

network upgrading;

■ constraints linked to:

- the industrial process,
- the electrical process,
- the utility,
- the climate and geography of the site,
- standards, regulations and local practices.

It is clear that not all the needs can be optimally met, which means that the network designer must endeavour to find the best compromise.

needs to be met

Safety of people

Even if not all countries have standards and rules, certain obvious principles must be adhered to:

- prohibiting access to energized parts (protection against direct contact),
- a system to protect against the rise in potential of metal structures (protection against indirect contact),
- prohibiting on-load line disconnecting switch operations,
- prohibiting earthing of live conductors
- quick fault clearance.

Safety of property

Electrical installations should not be submitted to stress that they are not able to withstand. The choice of materials and equipment is therefore of prime importance. Two electrical phenomena are to be considered in order to avoid fire and to limit destructive effects:

- overcurrent (short-circuits and overloads),
- overvoltage.

The solutions that are used must ensure at the least the following:
■ quick fault clearance and continued power supply to the fault-free sections of the network (discrimination),
■ supply of information on the type of initial fault, for quick servicing.

Continuous power supply to loads

Continuous power supply to the loads is necessary for the following reasons:

- safety of people, e.g. lighting;
- sustained production performance, e.g. glass wire drawing;
- productivity;
- operating convenience, e.g. simplified machine or workshop restart procedure.

Loads are divided into three groups according to their operating requirements:

- "normal" loads,
- "essential" loads,
- "sensitive" loads for which no absence of power supply is tolerated.

Network operating ease

In order to carry out their tasks safely and reliably, network facilities operators need the following:

- a network that is easy to operate in order to act correctly in the event of a problem or a manoeuvre;
- sufficiently sized switchgear and equipment, which require little maintenance and are easy to repair (maintainability);
- efficient means of control and monitoring which facilitate remote control of the network by real time centralization in a single location of all the information relating to the state of the "electrical process", under normal and disturbed operating conditions.

Minimum electrical installation cost

The minimum electrical installation cost does not necessarily mean the minimum initial cost, but the sum of three costs:

- initial investment cost,
- operating and maintenance costs,
- cost of production losses associated with the network design and protection plan (protection system used, choice of devices and settings).

Optimization of electrical energy

When a plant includes electrical energy generators, it is necessary to manage the energy supplied by the utility and the energy produced locally in the best manner possible.

A control and monitoring system makes it possible to optimize the cost of plant power consumption in accordance with:

- the contract with the utility (billing rates according to the time, day and season);
- the availability of the plant generators;
- industrial process requirements.

Network changes and future extensions

When designing an industrial network, it is of primary importance to make a careful assessment of the future development of the plants, especially when extensions are foreseeable.

Changes that are liable or due to be made in the future should be taken into account:

- in sizing the main power supply components (cables, transformers, switching devices),
 - in designing the distribution diagram,
 - in calculating the areas to be set aside for electrical rooms.
- This forward planning will result in increasingly flexible energy management.

Network upgrading

Electrical energy consumption increases as extensions are made to meet the needs of new types of manufacturing and ever more powerful machines. This makes it mandatory to upgrade and/or restructure the network.

Greater care must be taken in network upgrading analyses than in analyses of new installations since additional constraints are involved, i.e.:

- insufficient electrodynamic and dielectric strength of existing devices or equipment;
- capacity to supply power to large loads (starting current, dynamic stability, etc.);
- area and height of existing electrical rooms that cannot be changed;
- imposed geographical location of equipment and loads.

Example of upgrading with the addition of a new transformer: the installation of a three-phase reactor between the old installation and the transformer makes it possible to limit the increase in short-circuit current and therefore to continue using the existing equipment (see appendix 1).

Quality of analyses

The design analysis and detailed analysis must be carried out methodically and precisely. ISO 9001 certification entails setting up procedures which describe the essential steps involved in design and detailed analyses in the view of mastering these analyses and meeting the clients' needs in the best way possible.

Merlin Gerin's Contracting Department was granted ISO 9001 certification in 1992.

main constraints

Constraints linked to the industrial process

Apart from the need for a high level of continuous power supply in certain industrial processes, those very processes also impose constraints:

- power supply and, in particular, starting of very large motors which drive crushers, grinders, fans, pumps and conveyor belts (a major cause of voltage drops during starting);
- power supply to arc furnaces, the arc often being unstable, which causes brief but repeated unbalanced voltage drops (resulting in flicker), and can create harmonics;
- power supply to high capacity electronic devices (rectifiers, thyristors, etc.) which create major voltage wave deformations (harmonics) in the network and lower the power factor; this is the case for potlines, DC electric furnaces and variable speed drives.

In addition, some industrial processes pollute their environment. They produce substances (dust, gas) that are sometimes corrosive and can jam mechanisms or degrade the performance of electrical devices (e.g. dielectric strength) or even cause explosions in the presence of electric arcs.

Constraints linked to the electrical process

During the analysis, it is necessary to take into consideration various "electrotechnical" conditions that all electrical networks must fulfil, in particular:

- limitation of short-circuit currents and their duration
- starting or restarting of large motors without excessive voltage drops,
- stability of alternators after a disturbance has occurred.

Constraints imposed by the utility electrical power distribution network

■ short-circuit capacity
The short-circuit capacity of the upstream network supplying the private network is a decisive element when choosing:

- the structure of the private distribution network,
- the maximum load,
- particular loads that are sensitive to voltage drops.
- utility earthing system
The same type of earthing system, as used by the utility, is often used for the private network but it is sometimes not compatible with particular loads. In such cases, it is necessary to create a separate system with:
- a type of electrical protection for phase-to-earth faults,
- a special network operating method (fault tracking and/or clearing by operating personnel in the case of isolated neutral systems).

■ momentary dips or substantial transient single-phase or multiphase voltage drops.

The presence of such phenomena can cause disturbances, or even production shutdowns and machine destruction.

These phenomena may result in:

- operating errors and/or the loss of data of the industrial process computer

system (central computers, PLCs), and management control system as well as scientific calculation errors.

mechanical destruction of motors, motor coupling and/or the driven machines. This occurs during momentary dips (re-energizing of motors that are still in motion), since coupling may take place with phase opposition between the mains voltage and the residual voltage generated by the motor, this results in motor currents being very high, i.e. 4 to 5 times the rated current, and cause excessive electrodynamic stress.

■ overvoltage of external origin, in particular lightning strokes (refer to "Cahier Technique" n°168).

■ value and quality of the supply voltage:

the value of the supply voltage dictates to a certain extent the organization of private network voltages. If the power supply is in High Voltage, it may be of benefit to use that voltage level for the plant's main distribution system;

the quality of the supply voltage.

Various voltage fluctuations may bother or even prevent production equipment operation. The chart in figure 1 shows such faults, the causes and consequences, as well as the main remedies.

Remarks:

In terms of supply voltage quality, frequency deviations must be within $\pm 2\%$ and harmonic voltages must be less than 3%.

A major European national utility has installed more than 2000 recording devices on the power supply system for major industrial sites in order to assess the quality of the electrical power being supplied.

The devices measure:

- rms voltage and current;
- active and reactive power,
- short and long power outages,
- voltage dips,
- harmonic voltages and currents,
- voltage unbalance.

They also detect 175 and 188 Hz remote control signals.

Climatic and geographical constraints

In order to determine the best specifications for equipment and devices according to the types of

voltage fluctuations	a few %	5 to 25%	5 to 25%	100%
duration	1/100 to 1 s	0.5 to 20 s	20 s to 1 hour	0.1 to 0.3 s or 10 to 30 s
periodicity	YES	NO	NO	NO
causes	presence of electric arc furnace	<ul style="list-style-type: none"> ■ starting of large motors ■ single- or multiphase fault 	absence of voltage regulation in primary substations	fast and/or slow HV line reclosing system
consequences	variations in incandescent lighting (Flicker)	<ul style="list-style-type: none"> ■ risk of network instability 	<ul style="list-style-type: none"> ■ motor overload ■ high risk of network instability 	momentary suspension of power supply to all loads
main remedies	use static var compensation equipment	<ul style="list-style-type: none"> ■ change the starting method ■ increase protection plan rapidity 	equip the transformers with on-load tap changers	use shunt circuit breakers

fig. 1: voltage fluctuations, causes ,consequences and main remedies

installations, it is necessary to know the following:

- average and maximum daily temperatures,
- relative humidity rate at maximum temperature,
- maximum wind speed,
- presence of frost, ice, sand-bearing winds,

- environment (corrosive atmosphere or risk of explosion),
- altitude,
- frequency of lightning strokes in the region,
- difficulties in gaining access to the site (for the transport of materials and also for maintenance).

Compliance with standards and local practices

In this regard, it is especially important to be familiar with:

- national and/or international switchgear and installation standards,
- regulations and rules which apply specifically to the industrial complex,
- local practices.

2. main rules of industrial network design

The aim of this chapter is to explain how the industrial network design process takes into consideration all the obligations (needs and constraints) described in the previous chapter. Since plants are designed to operate non-stop, any break in the electrical power supply should be assessed during the analysis phase and the consequences examined in order to determine the measures to be taken. The method put forth in this chapter comprises two phases:

- 1 - endeavouring to achieve an appropriate technical balance between needs and constraints (see chapter 1),
- 2 - technical and economic optimization through the correct use of certain calculations and the concepts presented below.

Appendix 2, without being exhaustive, lists the main calculation software programs that are used by specialized network analysis engineers.

load survey, load and diversity factors

This is the first essential step in designing a network. It should define and geographically locate the power requirements.

Load survey

It is necessary to:

- distinguish active, reactive and apparent power;
- group the power demands by geographical area (3 to 8 areas) according to the size of the site;
- identify, for each area, the "normal" - "essential" and "sensitive" loads.

Load and diversity factors (see fig. 2)

choice of voltages

The choice of voltages is determined by the function that is to be performed: transmission, distribution or consumption. In HV, the distribution voltage is not necessarily the same as the consumer voltage. For example, 20 kV may be the optimal distribution voltage in a plant in view of the power flow and the distance of workshops

from the main substation, even if the ten largest motor loads require a nominal voltage of 6.6 kV.

reactive power compensation

The local utility generally establishes the minimum power factor (p.f.) for the client's supply point.

Reactive power compensation is often necessary to meet this requirement and may be carried out at two levels:

- at the substation (or main switchboard) level: **global** compensation;
- at the load level: **distributed** compensation.

The general principle of compensation using capacitors is presented in appendix 3.

Remark: strong compensation by means of fixed capacitor banks may cause overvoltage. A particular case of this is the phenomenon of the self-excitation of asynchronous machines: the capacitors that are associated with an asynchronous motor (distributed compensation) may give rise to very high overvoltage when there is a break in the power supply. This phenomenon can occur when compensation is greater than 90% of the magnetizing current, which is approximately equal to motor no-load current.

backup and replacement sources

Backup sources are installed to protect people (standards and laws), e.g. emergency exit route lighting. Replacement sources are installed in order to maintain production facilities

operation or to provide greater operating flexibility.

autonomous electrical energy production

A plant may have its own means of generating electrical power to supply its "sensitive" loads, for electricity billing rate reasons or when the plant's manufacturing process produces energy (thermal or mechanical), e.g. in the form of vapour.

If the utility network has a sufficient short-circuit capacity and voltage and frequency quality, it is preferable to operate the autonomous sources and the mains in parallel, since the mains help to stabilize the performance of the plant's alternators (voltage and speed). When parallel operation is used, a system for distributing active and reactive power between the different alternators and the mains should be included.

When serious electrical problems occur in the private network, or in the utility network near of the plant, instability may result. It may be necessary to separate the private network from the utility network (creation of an isolated network supplied by the alternators) within an extremely short time (about 0.2 seconds) so as not to risk a full facilities shutdown. Separation of the networks is generally accompanied by the disconnection of non-essential loads from the private network in order to avoid overloads.

division of sources

Certain loads cause a high degree of interference in the utility supply

	motors	lighting heating	power outlets
load factor	0.75	1	(**)
diversity factor	0.70 (*)	1	0.1 to 0.3

* Depends on the process

** Depends on the destination

fig. 2: general indication of load and diversity factors.

network. The division of sources (see fig. 3) is used to isolate the fluctuating loads and it offers two additional advantages as well:

- improved discrimination between the protection devices, thereby increasing continuous power supply to the other loads;
- adaptation of the earthing system to suit the loads.

overall electrical diagram

The network designer uses the various elements described earlier in this chapter to establish a preliminary structure, which he then fine-tunes in accordance with the constraints of the industrial site to obtain the "overall single-line diagram" of the plant's electrical distribution system. This is the starting point for technical and economic network optimization. The next chapter presents the different choices that are available and the calculations that are required to find the optimal solution.

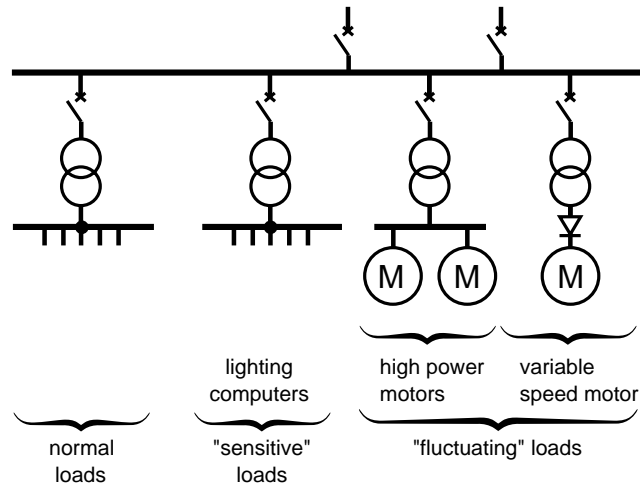

fig. 3: the division of sources is a means of separating the "fluctuating" loads from the other loads.

3. validation and technical and economic optimization

choice of the earthing system

Standards and regulations make protection against direct and indirect contact compulsory for all electrical installations. In general, protection functions automatically interrupt the power supply (upon the first or second phase-to-earth fault according to the earthing system used). There are also special protection devices designed for specific situations. High Voltage network earthing systems may be chosen according to the criteria given in appendix 4.

However, it is very often of benefit to use different earthing systems in the same industrial network, each of which provides a predominant advantage.

feeder definition

Feeders account for a large portion of electrical installation investment. It is therefore important, for safety and cost reasons, to:

- choose the best type of equipment (cables),
- make the most accurate calculations of the minimum cross section, while taking into account short-circuit and starting currents, voltage drops, losses, etc.

insulation coordination analysis

The coordination of insulation provides the best technical and commercial compromise in protecting people and equipment against the overvoltage that may occur in electrical installations, whether such overvoltage originates from the network or from lightning.

Three types of overvoltage may cause flashovers and hence insulation faults, with or without destruction of the equipment:

- power frequency overvoltage (50 to 500 Hz),
- switching surges,

- atmospheric overvoltage (lightning strokes).

Insulation coordination contributes to obtaining greater electrical power availability. Correct insulation coordination entails:

- knowing the level of overvoltage that is liable to occur in the network;
- specifying the desired degree of performance or, more explicitly, the acceptable insulation failure rate;
- installing protection devices that are suited to both the network components (insulation level) and the types of overvoltage;
- choosing the various network components based on their level of overvoltage withstand, which must meet the constraints described above.

"Cahier Technique" n° 151 describes voltage disturbances, ways of limiting them and the measures set forth in the standards to ensure dependable, optimized electrical energy distribution, thanks to insulation coordination.

protection system definition

When a fault appears in an electrical network, it may be detected simultaneously by several protection devices situated in different areas of the network. The aim of selective tripping is to isolate as quickly as possible the section of the network that is affected by the fault, and only that section, leaving all the fault-free sections of the network energized. The network designer must first of all select a protection system that will enable him to specify the most suitable protection devices. He must also create a relay tripping plan, which consists of determining the appropriate current and time delay settings to be used to obtain satisfactory tripping discrimination.

Different discrimination techniques are currently implemented, which use or combine various data and variables such as current, time, digital

information, geographical arrangements, etc.

Current discrimination

Used (in Low Voltage) when short-circuit current decreases rapidly as the distance increases between the source and the short-circuit point being examined, or between the supply and load sides of a transformer.

Time discrimination

Used in Low Voltage and very often in High Voltage as well. Protection device (circuit breaker) tripping time delays are increased as the devices become closer to the source. In order to eliminate the effects of transient currents, the minimum time delay at the furthest point from the source (directly upstream from the load) is 0.2 s or even 0.1 s if the current setting is high, with a maximum time delay of 1 s at the starting point of the private network.

These time delays may be definite time or short-circuit current dependent.

Discrimination by logical data transmission, or logical discrimination

This type of discrimination consists of the transmission of a "blocking signal" of a limited duration, by the first protection unit situated directly upstream of the fault, and which is supposed to open the circuit, to the other protection units situated further upstream.

This technique, which has been developed and patented by Merlin Gerin, is described in detail in "Cahier Technique" n° 2.

The tripping time delay is short and definite, wherever the fault may be situated in the network. This helps increase to the dynamic stability of the network and minimizes the damaging effects of faults and thermal stress.

Discrimination using directional or differential protection

This type of discrimination provides specific protection of a portion or particular element of the network.

Examples: transformers, parallel cables, loop systems, etc.

Discrimination using distance protection

This type consists of splitting the network into zones. The protection units locate the zone area in which the fault is situated by calculating the circuit impedance.

This technique is seldom used except when the private HV network is very widespread.

An example of a protection system that uses several discrimination techniques is given in figure 4.

N.B. The criteria used for selecting protection systems, relays and protection settings are not discussed in this section. A number of other publications deal with those matters, e.g. "Cahiers Techniques" n° 2 and 158.

short-circuit current calculation

In order to find the best technical and economic solution, it is necessary to know the different short-circuit values so as to determine:

- making and breaking capacity according to the maximum peak and rms short-circuit current;
- equipment and switchgear resistance to electrodynamic stress, according to the maximum peak short-circuit current;
- protection tripping settings in discrimination analyses according to the maximum and minimum rms short-circuit current.

"Cahier Technique" n° 158, after reviewing the physical phenomena to be taken into consideration, reviews the calculation methods set forth in the standards.

When rotating machines (alternators or motors) are included, the form of short-circuit current can be broken down into three portions:

- subtransient,
- transient,
- steady state.

The subtransient and transient stages are linked to the extinction of the flux

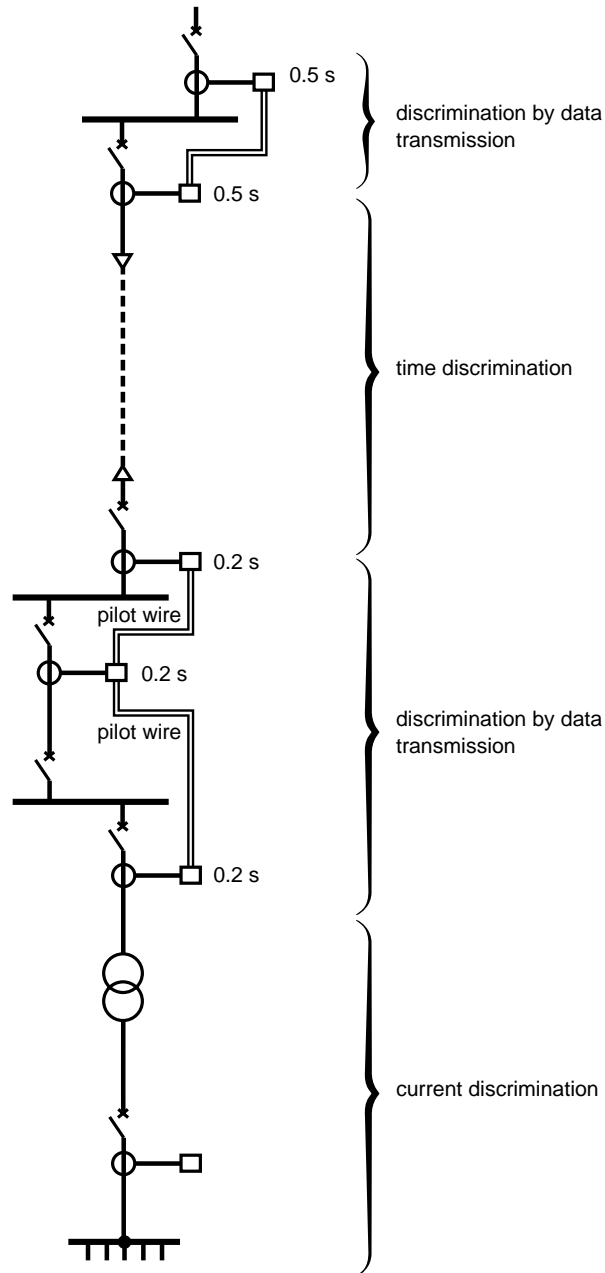

fig. 4: protection system using several discrimination techniques: current, time and logic.

built up in the synchronous and asynchronous rotating machines. In both of these stages, it is necessary to deal with the aspect of an

asymmetrical component, also referred to as a DC component, the damping of which depends on the R/X ratio of the upstream network and the timing of the

fault with respect to the phase of the voltage.

In addition, it is necessary to take into account motor contribution to short-circuit current. When a three-phase short-circuit occurs, asynchronous machines are no longer supplied with power by the network, but the magnetic flux of the machines cannot suddenly disappear.

The extinction of this flux creates a subtransient and then transient current which intensify the short-circuit current in the network.

The total short-circuit current is the vectorial sum of two short-circuit currents: source short-circuit current and machine short-circuit current.

calculation of voltage fluctuations under normal and disturbed operating conditions

Normal operating conditions

The calculation of voltage fluctuations under normal operating conditions is a design task which serves to verify the voltages throughout the network.

If the voltages are too low, the network designer should verify whether:

- the active and reactive power flows are normal,
- the feeders are correctly sized,
- the transformer power ratings are sufficient,
- the reactive power compensation scheme is appropriate,
- the correct network structure is being used.

Disturbed operating conditions

It is necessary to calculate voltage fluctuations under disturbed operating conditions in order to verify whether the following phenomena will result in excessive voltage drops or rises:

- starting of large motors (see fig. 5),
- downgraded network operation (e.g. 2 transformers operating instead of the 3 intended for normal operation),
- no-load network operation, with or without reactive power compensation.

Appendix 5 gives the mathematical expression and vector diagram of a network voltage drop.

choice of motor starting method

The starting method used (delta-star, autotransformer, resistors or stator reactors, etc.) must obviously provide sufficient accelerating torque (accelerating torque is generally greater than 0.15 times the rated torque), and, in addition, must only cause acceptable voltage drops (< 15%).

Reminder: the equation governing the interaction of the motor with the driven mechanism is:

$$T'm - T_r = J \frac{d\omega}{dt}$$

$T'm$ = motor torque when energized at actual supply voltage (U_r),

T_r = braking torque of the driven machine,

J = inertia of all the driven masses,

$d\omega/dt$ = angular acceleration,

$T'm = T_m \left(\frac{U_r}{U_n} \right)^2$

T_m = motor torque when energized at rated voltage (U_n).

$T_a = T'm - T_r$

T_a = accelerating torque.

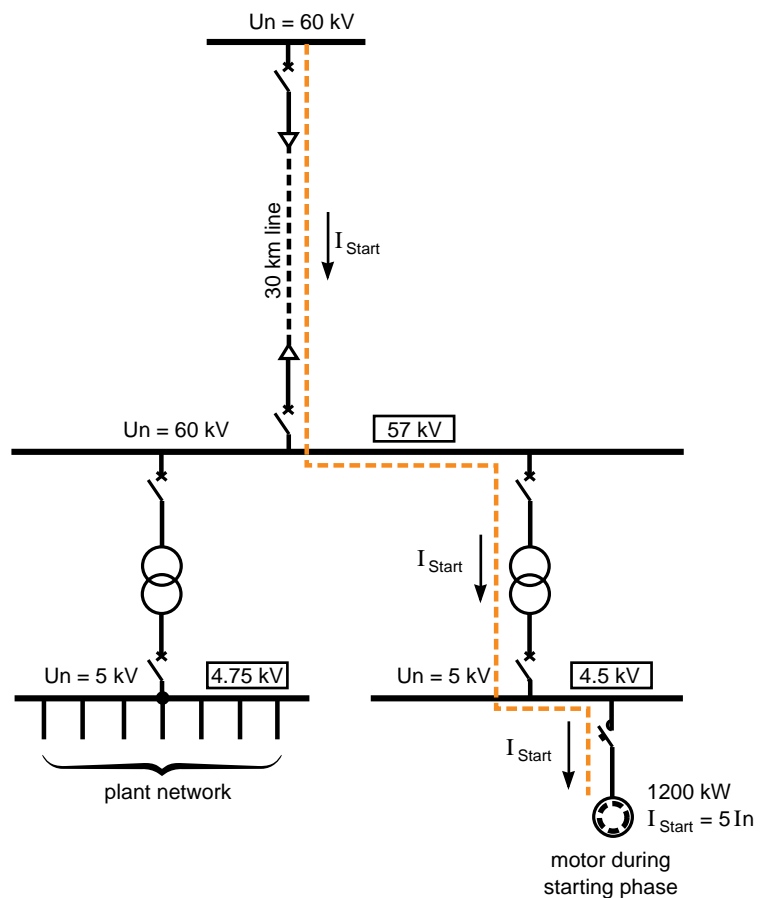

fig. 5: example of the determination of voltage dips during motor starting for the installation of a 1200 kW motor supplied by a 30 km long, 60 kV line. It should be noted that separation of the "plant network" power supply and the motor power supply have made it possible to have a voltage drop of only 250 V in the "plant network".

xx kV = voltage during motor starting

The curve showing T_a as a function of speed is given in figure 6 below.

The chart in figure 7 shows the most frequently used starting methods (for further details, please refer to "Cahier Technique" n° 165).

network dynamic stability

Under non-disturbed operating conditions, all the rotating machines (motors and alternators) included in the installation form a stable system with the utility network.

This equilibrium may be affected by a problem in one of the networks (utility or private), such as: major load fluctuation, change in the number of transformers, lines or supply sources, multiphase fault, etc.

This results in either short-lived instability, in the case of a well-designed network, or a loss of stability if the disturbing phenomenon is very serious or if the network has a low recovery capacity (e.g. short-circuit capacity too low).

Asynchronous motor performance in the presence of a three-phase fault

Here, as an example, is the analysis of asynchronous motor performance in the presence of a three-phase fault (see fig. 8).

After the fault has been cleared, two situations may occur:

- the motor torques are greater than the braking torques, in which case the motors can reaccelerate and return to their stable state;

- the motor torques are less than the braking torques, in which case the motors continue to slow down, drawing large currents which are detected by the motor and/or network protection devices, which trip the related circuit breakers.

Motor reacceleration, and hence network dynamic stability, are favoured by:

- a suitable load shedding plan (tripping of normal, non-essential motors in the event of serious faults);
- a powerful network (correctly regulated alternators and low voltage drop);

- fast-acting protection systems which reduce the duration of motor slowdown (e.g. logical discrimination);
- a suitable network structure with:

- separation and regrouping in separate circuits of normal, non-essential loads and essential and sensitive loads, which facilitates load shedding,
- minimal impedance connections for essential and sensitive loads so as to limit voltage drops.

The duration of the return to normal motor speed depends on:

- motor accelerating torque, and hence voltage drop,
- rotating machine inertia.

Calculation software may be used to simulate the dynamic performance of electrical networks, making it easier to

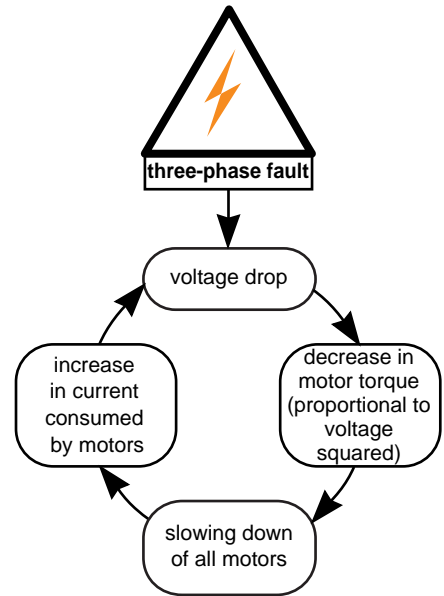
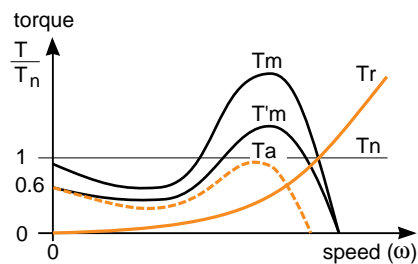

fig. 8: performance of asynchronous motors in the presence of a three-phase fault



T'_m = motor torque when energized at the actual supply voltage (U_r),
 T_r = braking torque of the driven machine
 T_m = motor torque when energized at the rated voltage (U_n)
 T_a = accelerating torque

fig. 6: diagram of different motor torques according to speed, with a voltage drop of about 15% (hence $T'_m = 0.7 T_m$) and braking torque $T_r = 0$ during starting. It should be noted that this voltage drop would not allow the motor to be started with a $T_r > 0.6 T_n$ when started, since $T_r > T'_m$.

application needs	application characteristics	starting method	advantages drawbacks
continuous or virtually continuous process starts ≤ 1 per day	machines that require strong starting torque	direct	simplicity, reduced investment. upon starting: ■ strong torque, ■ high inrush current, ■ strong mechanical stress.
frequent starts > 1 per day pumps, fans, compressors, frequent starts	motors with low inrush current or low power machines that start with weak torque	direct stator- reactor	reduction of torque and inrush current upon starting (adjustment possible).
optimization of starting characteristics	when starting current needs to be reduced while maintaining the torque needed for starting	stator - autotransformer	optimization of torque (reduced) and inrush current upon starting (adjustment possible).
optimization of strong torque starting characteristics	the most difficult starts	rotor	low inrush current and strong starting torque.

fig. 7: the most commonly used starting methods

make the correct choices, in particular, when establishing the procedures to be used to separate power supply sources (creation of "isolated systems"), non-essential load shedding plans and protection systems (logical discrimination for very short tripping times). All of these factors contribute to maintaining the dynamic stability of the network when disturbances occur.

To summarize:

If the disturbance is minor (two-phase short-circuit far from the load), stability is restored by speed and voltage regulators. When there is a high risk of instability, it is necessary to include a protection device that will clear the fault within a very short time (0.2 to 0.3 s) and/or a device to divide the network so

as to sustain it (load shedding) and avoid the risk of a complete installation shutdown (see fig. 9).

synthesis

All of the information presented in this chapter is summarized in a logic diagram in appendix 6.

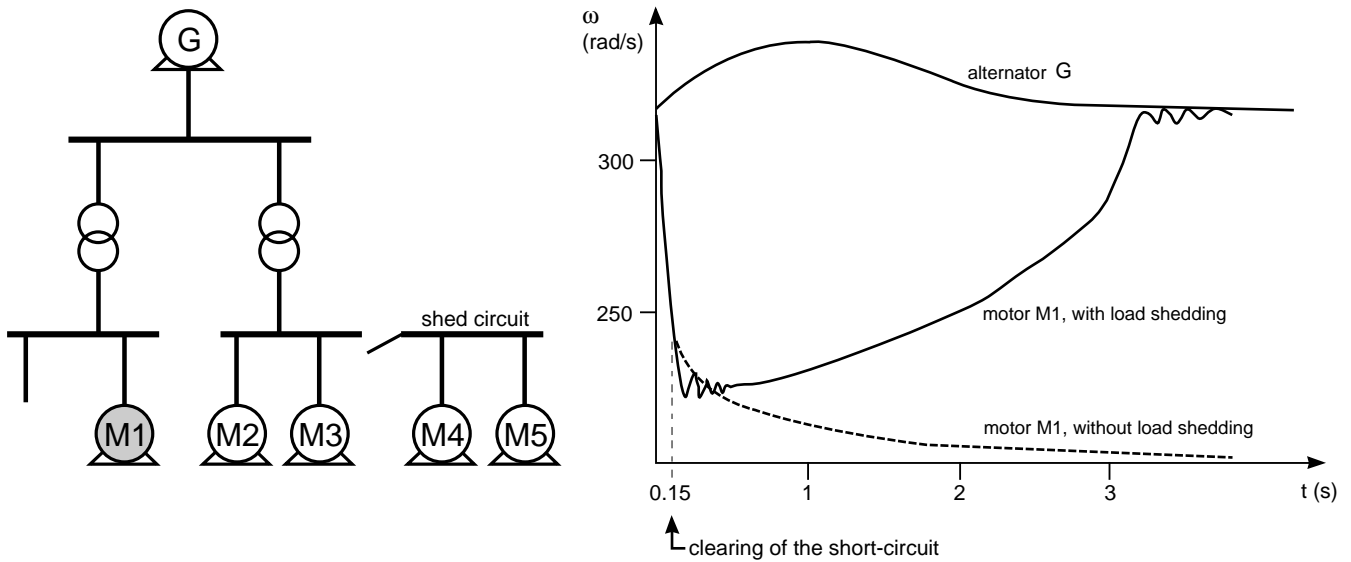

fig. 9: presentation of the dynamic performance of a network with and without load shedding

4. choice of optimal network structure and operation

Different network structures are possible, the most common of which are described in this chapter together with the main areas in which they are used.

The choice of a network structure, which is always a decisive factor in terms of energy availability, is often a difficult one to make.

The most rational method consists of making a quick comparison of the unavailability of voltage at a particular point in the network for different structures and using a very interesting expert system (see appendix 2).

standard network structures

Open or closed loop, also called "primary loop system"

(see fig. 10)

Recommended for very widespread networks, with major future extensions. Open loop operation is advisable.

Double radial feeder, also called "primary selective system" (manual or automatic)

(see fig. 11)

Recommended for very widespread networks with limited future extensions and which require a high level of continuous power supply.

Radial feeder, also called "single power supply"

(see fig. 12 on the opposite page)

Recommended when continuous power supply requirements are limited. It is often used for cement plant networks.

Dual power supply

(see fig. 13 on the opposite page)

Recommended when a high level of continuous power supply is required or when the operating and maintenance teams are small.

It is very often used in the steel and petrochemical industries.

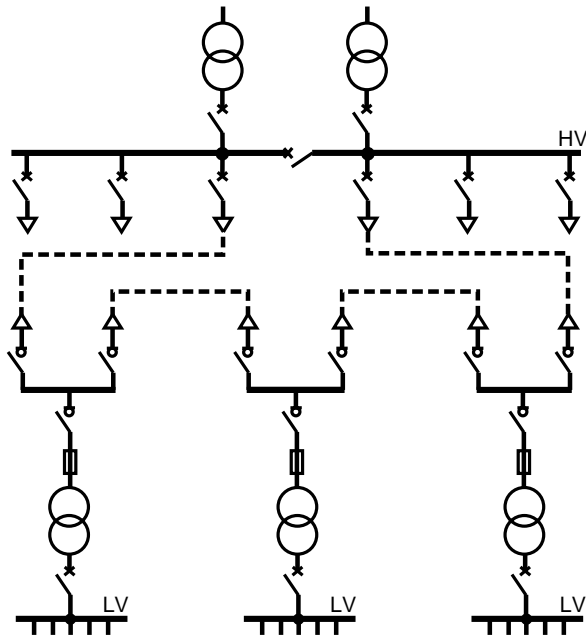

fig. 10: diagram of a primary loop.

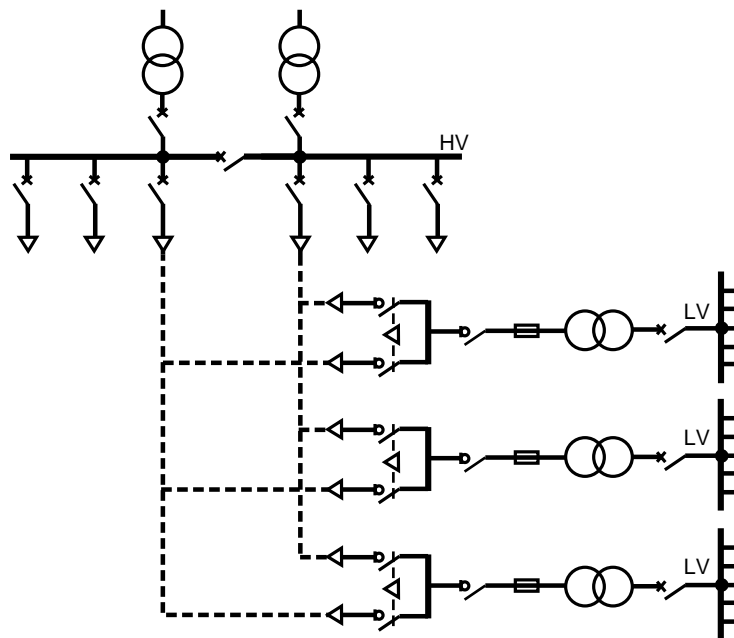

fig. 11: diagram of a primary selective network.

Dual busbar

(see fig. 14)

Recommended when a very high level of continuous power supply is required or when there are very strong load

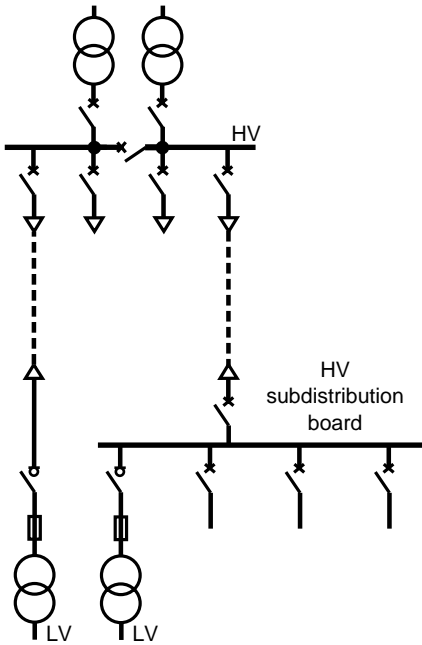

fig. 12: diagram of a single power supply network.

fluctuations. The loads may be distributed between the two busbars without any break in the power supply.

With energy generating sets

(see fig. 15)

This is the simplest structure, and is very often used.

With replacement source and load shedding

(see fig. 16)

This is the typical case for an industrial network in which a very high level of continuous power supply is required using a single power supply source, i.e. the utility.

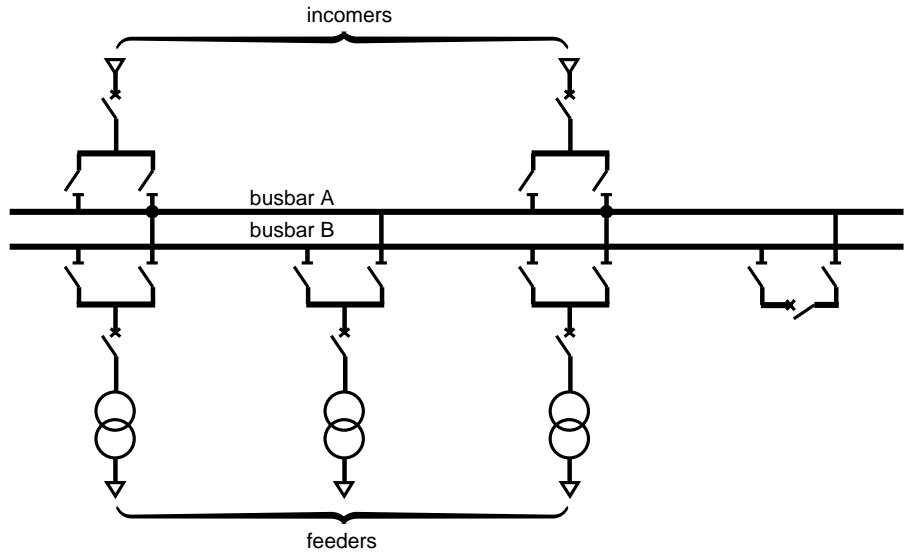

fig. 14: diagram of a dual busbar network.

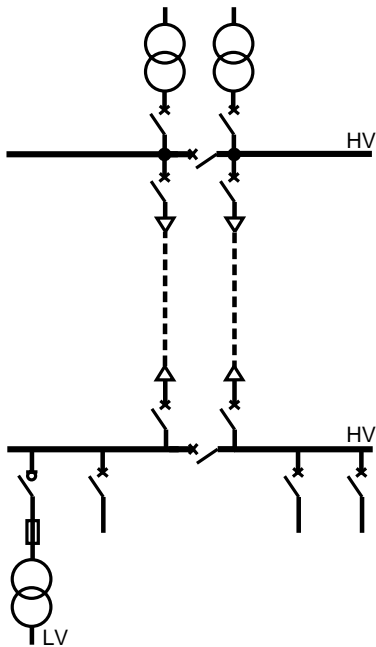

fig. 13: diagram of a dual power supply network.

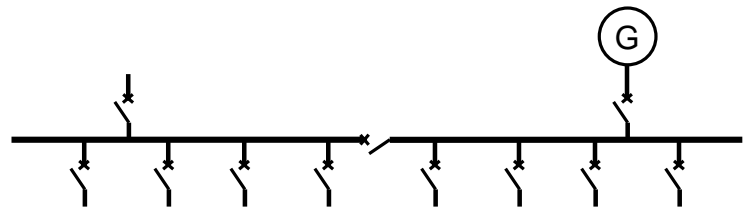

fig. 15: diagram of a network with local generation.

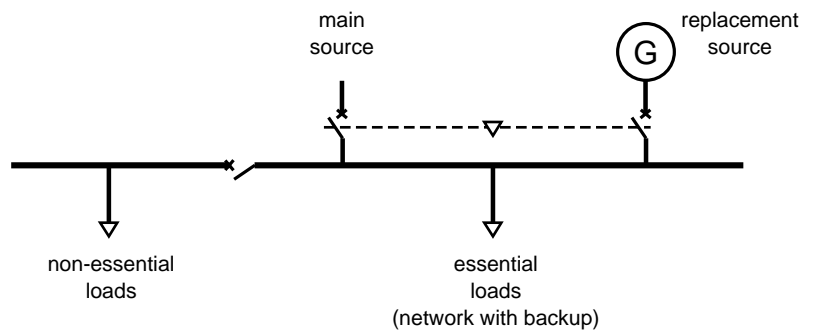

fig. 16: diagram of a network with a replacement source and load shedding.

concrete example of a structure

The diagram in figure 17 was designed and developed for a multi-metal mine in Morocco. It includes different network structures that were described earlier. The power supply to the various workshops is provided by a loop, a duplicate feeder, or a main source and replacement source.

choice of equipment

Whatever the structure that is used, the equipment must comply with:

- standards in effect;
- network characteristics:
 - rated voltage and current,
 - short-circuit current (making and breaking capacity, electrodynamic and thermal withstand);
- the required functions (fault breaking, breaking in normal operation, frequency control, circuit isolation, etc ...);
- continuous power supply requirements (fixed, disconnectable, withdrawable switchgear);
- operating and maintenance staff qualifications (interlocks, varying degrees of automatic control, breaking technique requiring maintenance or maintenance-free);
- requirements related to maintenance and possible extensions (extra space for future use, modular system, etc.).

N.B. At this stage of the analysis, all the network characteristics result from calculations that are often carried out using scientific calculation software.

optimal operation

Optimal electrical distribution system operation means finding:

- the best level of continuous power supply,
- minimum energy consumption cost,
- optimization of the operating and maintenance means which contribute to correct network operation, both steady state and transient, and in the presence of a fault.

The solution lies in the implementation of an electrical Energy Management System for the entire network.

The Energy Management Systems that are currently offered by manufacturers, such as Merlin Gerin, make full use of microprocessor performance. These

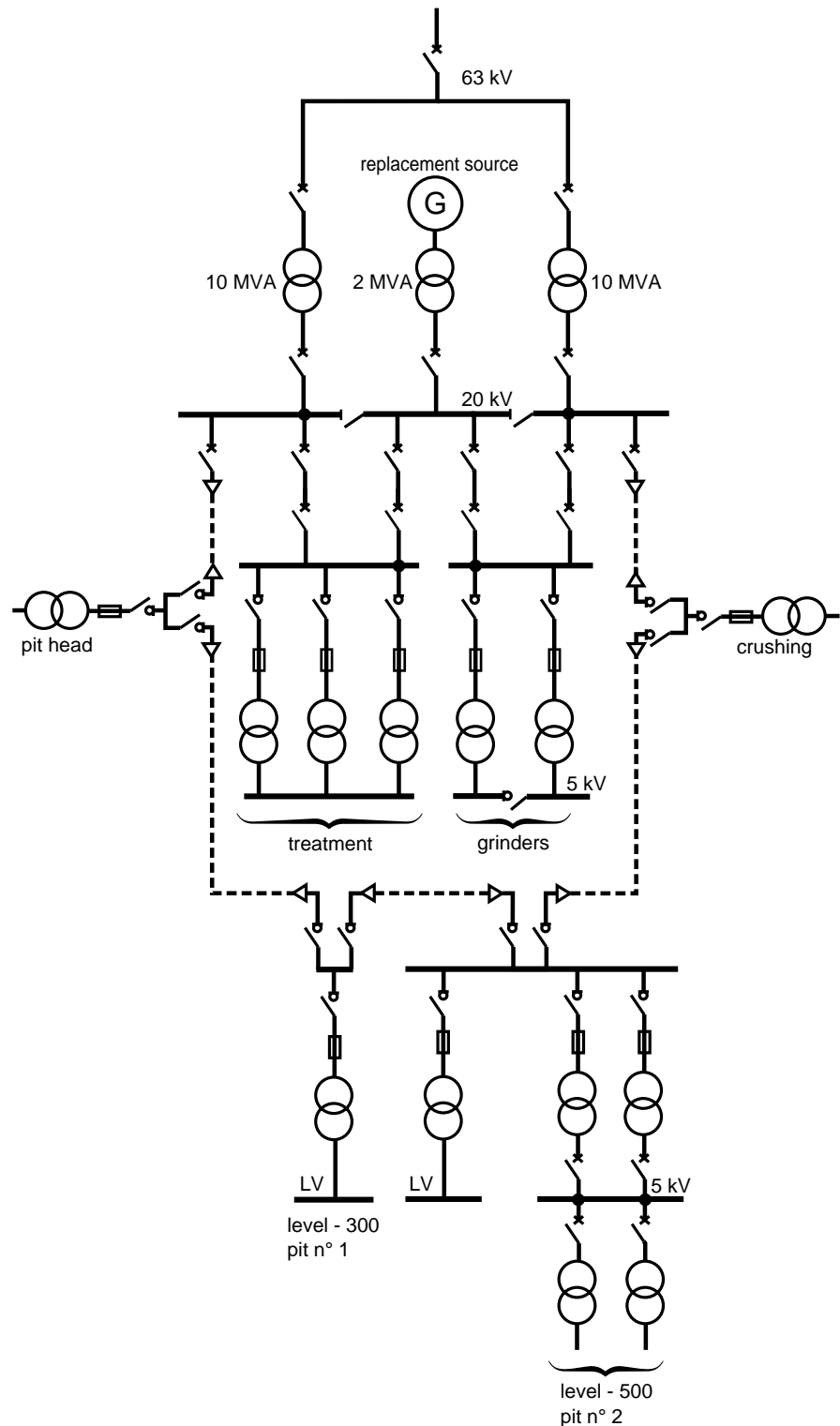

fig. 17: structure of the electrical network of a Moroccan mine (Merlin Gerin).

components, integrated in local and remote management centres, and in the protection and control gear installed at the actual energy consumption sites, are at the origin of the concept of "decentralized intelligence". The term "decentralized intelligence" means that the control centres and devices autonomously carry out their assignments at their levels (without any human intervention) and do not call upon the "upper" level except when failures occur. The remote monitoring and control system continuously informs the network manager or user of changes. This explains the importance of clearly specifying the network architecture.

Description of an Energy Management System

(see fig. 18)

Energy Management Systems are set up in four levels:

- level 0: sensors (position, electrical variables, etc.) and actuators (trip units, coils, etc.);
 - level 1: protection and control units, e.g. HV cubicle;
 - level 2: local control, e.g. a HV/LV substation of a plant or LV switchboard in a workshop;
 - level 3: remote control of an entire private network.
- All this equipment, particularly levels 1 to 3, is linked by digital communication

buses (networks via which the information is conveyed).

Assignments carried out by Energy Management Systems

- managing energy supply and consumption according to:
 - subscribed power,
 - utility billing rates,
 - availability of the private generating station,
 - industrial process requirements.
- maintaining continuous power supply through:
 - quick, discriminating protection (e.g. logical discrimination system),
 - automatic power supply source changeover,

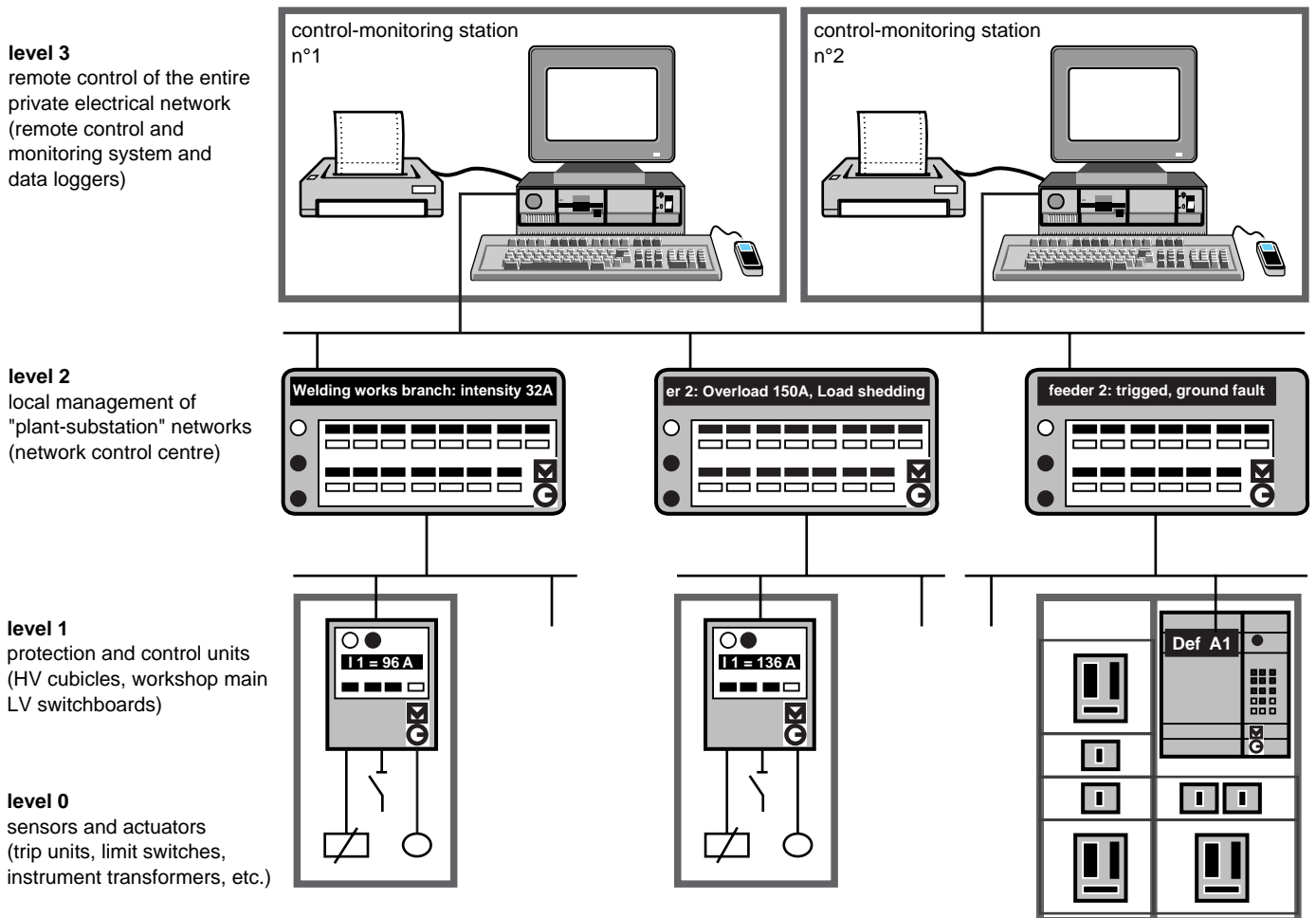

fig. 18: example of Energy Management System architecture.

- efficient load shedding/reconnection, the parameters of which can be set via the man/machine interface with the establishment of load shedding criteria (load shedding/reconnection plan);
- sequential workshop restarting,
- adjustment of voltage, power factor, etc.
- maintaining power supply to essential loads during outages of the utility supply the local alternators.
- enabling man/machine dialogue:
 - real time display of network and equipment status via mimic diagrams (single-line diagrams, detail diagrams, curves, etc.);
 - remote control of switching devices;
 - data and measurement logging,
 - chronological recording of faults and alarms (10 ms),
 - filing of events,
 - metering, statistics,
 - archiving.

All this data is used, in particular, to organize preventive maintenance.

- drawing up "User Guide" procedures which, for example:
 - prohibit the starting of particular motors according to the power available from the generating station, the time, or the degree of priority of the motors,
 - prohibiting the use of particular High Voltage switchboard power supply configurations (paralling of supplies),
 - proposing the most suitable backup arrangement for serious faults in a main feeder or a generator,
 - proposing operating instructions and maintenance operations (electrical, mechanical, etc.).

Advantages of an Energy Management System

The development of level 1 digital protection and control systems and the rapid rise in the performance/cost ratio

of level 2 hardware and software provide industrialists with technical and economic benefits, in particular:

- increased operating dependability;
- a broader range of accessible functions, especially data logging, preventive maintenance and remote control,
- easier commissioning and more efficient operation.

The richness of the functions that are offered by these systems, new possibilities for self-testing or even self-diagnosis and monitoring, as well as the user-friendliness of the user dialogue interfaces, naturally make the facilities manager's role more effective and interesting. The facilities manager is better able to assess the operation of his network and to optimize, apart from remote monitoring and control, maintenance and renewal of his electrical equipment.

5. conclusion

Well-mastered electrical network design makes it possible to ensure optimal operation under normal and disturbed network operating conditions. The best cost does not necessarily mean the minimum initial investment, but rather the design of an electrical network which proves to be the most economical from the viewpoint of initial

investment, operating costs and production losses.

The best operating conditions provide a level of continuous power supply to loads which is compatible with installation requirements, in the aim of obtaining maximum productivity and maximum safety of people and property.

The new generations of electrical switchgear and equipment are designed to communicate, via digital communication buses, with one or more control centres. And it is the combination of both networks, the energy network and the information network, at an acceptable investment cost, which provides optimal fulfilment of users' needs.

appendix 1: extension of an existing industrial network

The extension of an existing industrial network by adding a transformer that can be connected parallel to the existing transformer has the drawback of increasing short-circuit current strength and also of making it necessary to increase:

- the breaking and making capacity of the existing devices,
- the old installation's resistance to electrodynamic stress.

The installation of a three-phase reactor between the old and new facilities eliminates these difficulties (see fig. 19).

hypotheses

- short-circuit current of the existing installation: 17 kA (I_{sc1}),
- short-circuit current in the existing busbar must be limited to 21 kA (I_{sc2}), $X_{Tr} = 0.63 \Omega$.

approximate calculation of a current limiting reactor (resistors neglected)

The current flowing through the reactor should be equal, in the first approximation, to:

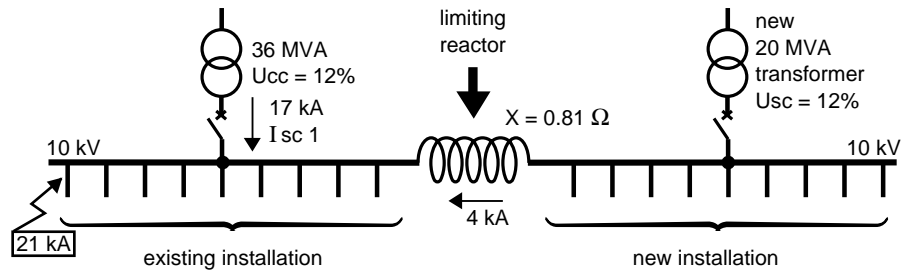

fig. 19: extension of an existing industrial network by addition of an extra transformer.

$$21 - 17 = 4 \text{ kA} = I_{scL}$$

I_{scL} = current limited by the reactor

$$= \frac{V}{X}$$

X = total reactance (20 MVA transformer and limiting reactor)

$$X = \frac{V}{I_{scL}} = \frac{10,000}{\sqrt{3} \times 4,000} = 1.44 \Omega$$

$$X = X_{react} + X_{Tr}$$

$$X_{Tr} = 0.63$$

$$X_{react} = 1.44 - 0.63$$

$$X_{react} = 0.81 \Omega$$

appendix 2: computerized means used for network analyses

Here is a list of the main software programs used in Merlin Gerin's different departments that are responsible for analyzing and/or designing electrical networks.

calculation software programs

- load flow study,
- short-circuit currents,
- voltage drops,
- network dynamic stability,

- harmonic currents and voltages,
- lightning and switching voltage surges,
- transformer and capacitor switching,
- unavailability of electrical power supply.

expert system for evaluating electrical network design quality

An expert system called ADELIA has been developed and is used by

Merlin Gerin. It is used to make a quick comparisons of the unavailability of voltage at a particular point in the network using distribution schemes. It offers the advantage of requiring fewer calculations than the Markov graph method, and also of providing both qualitative information (graph of combinations of events which lead to system failures), and quantitative results (network unavailability calculations).

appendix 3: general principle of compensation

The principle of compensation using capacitors may be illustrated by the two figures opposite.

■ figure 20 shows the vectorial composition of the different currents and for a given active current, the reduction in the total current in the conductors.

I_a = active current consumed
 I_{t_1} = total current prior to compensation
 I_{r_1} = reactive current supplied via the transformer prior to compensation
 I_{t_2} = total current after compensation
 I_{r_c} = reactive current supplied by the capacitor
 I_{r_2} = reactive current supplied by the transformer after compensation ($I_{r_2} = I_{r_1} - I_{r_c}$)

■ figure 21 illustrates the local exchange of reactive power which takes place between the load and the capacitor. The total current supplied by the network I_{t_2} is reduced and the

installation output is thereby improved since losses due to the Joule effect are proportional to the square of the current.

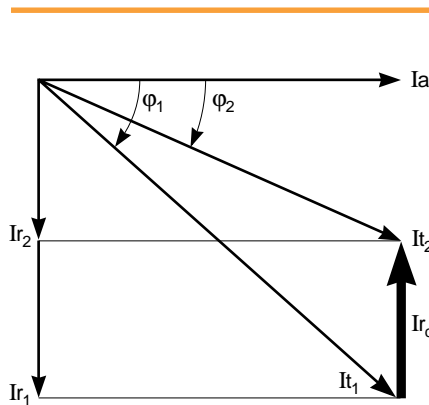

fig. 20: phasor diagram of the different currents and the effect of compensation.

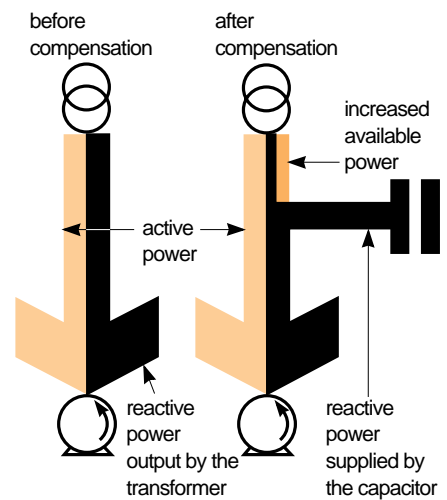

fig. 21: diagram depicting the energy exchange in a consumer circuit and the advantage of compensation.

appendix 4: choice of the earthing system for a HV industrial network

The choice of the earthing system for a High Voltage industrial network involves the following criteria:

- general policy,
- legislation in effect,
- constraints related to the network,
- constraints related to network operation,

- constraints related to the type of loads,
- etc.

Five diagrams may be considered:

- directly earthed neutral,
- reactance- earthed neutral,
- resonant- earthed neutral,
- resistance- earthed neutral,

- isolated neutral.

Each of them offers advantages and drawbacks with which the network designer should be familiar before making his final choice. They are listed in the chart below (see fig. 22).

directly earthed neutral diagram	advantages	drawbacks	in practice
directly earthed neutral	<ul style="list-style-type: none"> ■ facilitates earth fault detection and protection discrimination, ■ limits overvoltage 	causes high earth fault currents (dangerous for personnel and risk of major equipment damage)	not used
reactance-earthed	limits earth fault currents	<ul style="list-style-type: none"> ■ requires more complex protection than direct earthing, ■ may cause severe overvoltage, depending on installation configurations 	applicable without any particular precautions only if the limiting impedance is low with respect to the circuit's earth fault resistance
resonance-earthed (Petersen coil)	is conducive to self-extinction of earth fault current	requires complex protection (directional devices that are difficult to implement)	<ul style="list-style-type: none"> ■ sometimes used in Eastern countries ■ not used in France
resistance-earthed	<ul style="list-style-type: none"> ■ limits earth fault currents, ■ facilitates earth fault current detection and protection discrimination, ■ limits overvoltage 		the most beneficial for industrial distribution: it combines all the advantages
isolated from earth	limits earth fault currents	<ul style="list-style-type: none"> ■ risk of overvoltage ■ requires the use of over-insulated equipment (line voltage between phase and earth when a zero impedance fault occurs), ■ overvoltage protection advisable, ■ insulation monitoring obligatory (French law), ■ complex discrimination between earth fault protection devices 	no tripping when the first earth fault occurs entails: <ul style="list-style-type: none"> ■ being granted special dispensation (French law) ■ that the capacitance between active network conductors and earth do not cause earth fault current that is dangerous for personnel and machines.

fig. 22: advantages and drawbacks of the different earthing diagrams used for a HV industrial network.

appendix 5: network voltage drops (mathematical expression and vector diagram)

Voltage drops in a network may be calculated using the following mathematical expression:

$$\Delta V = R I \cos \varphi + X I \sin \varphi$$

The electrical diagram and vector diagram which correspond to this equation are given in figure 23.

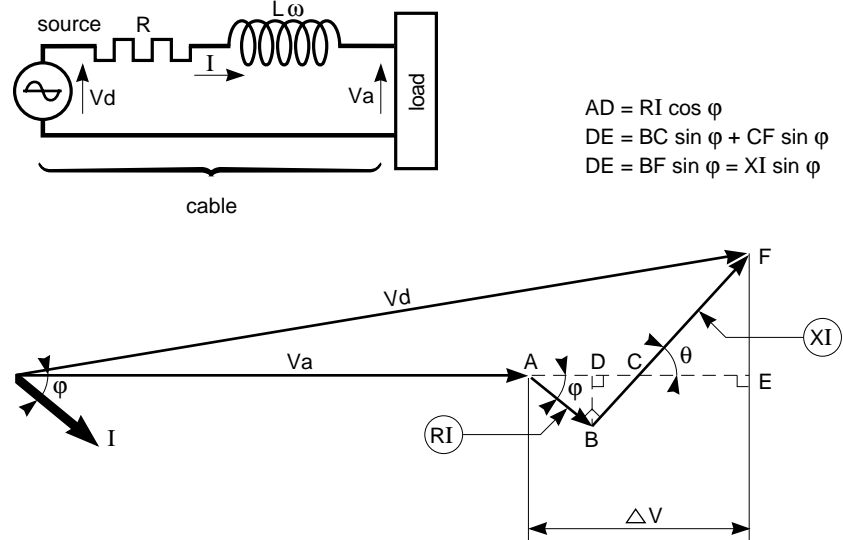

fig. 23: phasor diagram of network voltage drop

appendix 6: stages in industrial network design

This logic diagram comprises two loops:

■ the first one, the analysis and selection loop, starts at "Needs and constraints to be met" and leads to the

organization of a network structure in an "Overall single-line diagram";

■ the second is aimed at optimization of the structure.

- analysis and selection loop leading to the organization of a structure
- structure optimization loop

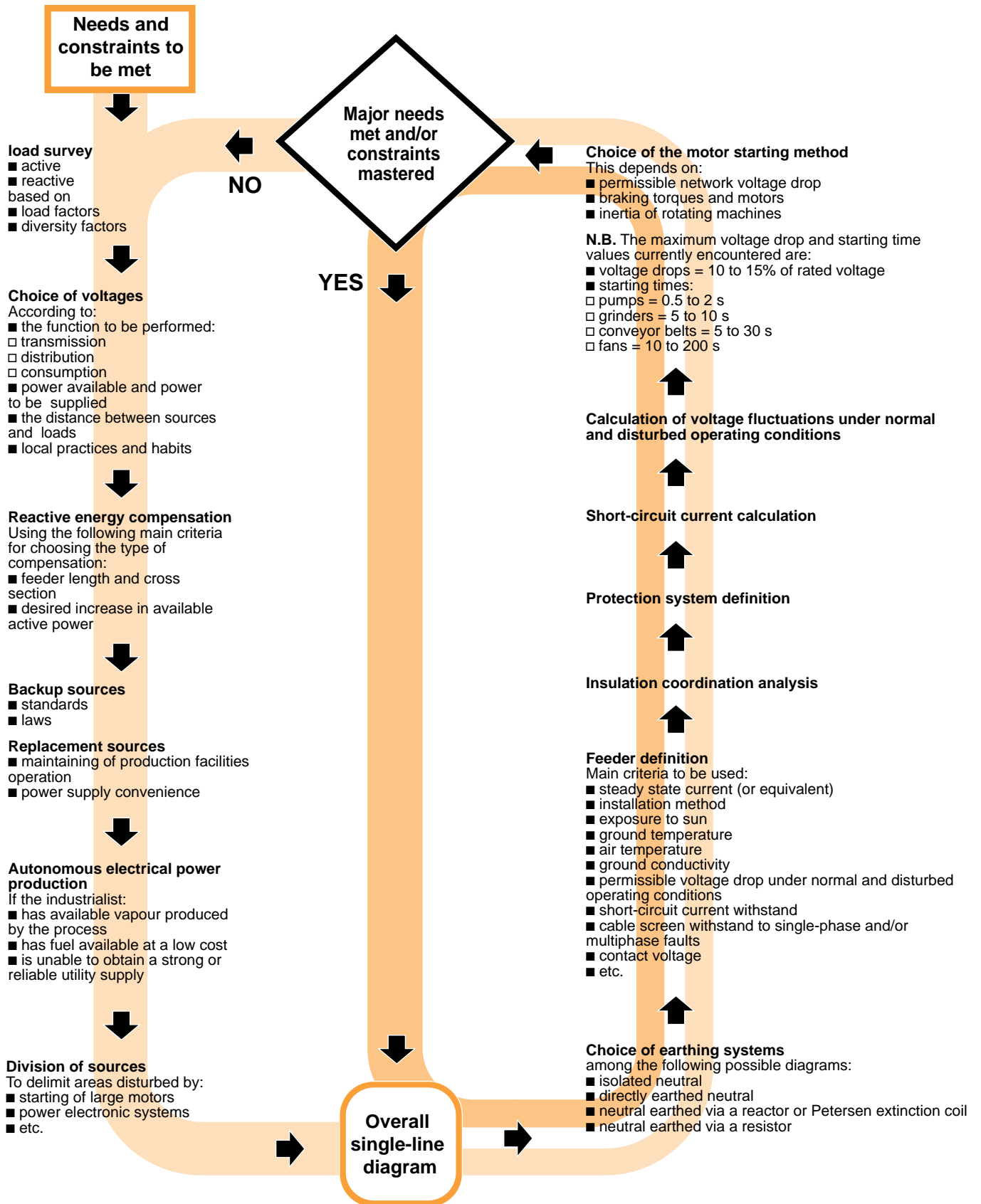

appendix 7: bibliography

Merlin Gerin Cahiers Techniques

■ Protection of electrical distribution networks by the logic selectivity system
Cahier Technique n° 2

F. SAUTRIAU

■ Mise à la terre du neutre dans un réseau industriel haute tension

Cahier Technique n° 62

F. SAUTRIAU

■ Gestion de l'énergie dans les processus industriels

Cahier Technique n° 133

C.G. POUZOLS

■ Surtensions et coordination de l'isolement,

Cahier Technique n° 151

D. FULCHRION

■ Calcul des courants de court-circuit,
Cahier Technique n° 158

R. CALVAS, B. DE METZ NOBLAT,
A. DUCLUZAU and G. THOMASSET

■ Lightning and HV electrical installations,

Cahier Technique n° 168

B. DE METZ NOBLAT

Miscellaneous publications

■ Overvoltage when clearing short-circuits from networks with a reactance-earthed neutral system.

Bulletin de la société Française des Electriciens, series 8, Volume 1, n° 4
(April 1960)

LE VERRE